

Onsite Wastewater Treatment System Regulations



***Amador County Environmental Health
Department***

Table of Contents

I. PURPOSE	5
II. DEFINITIONS	6
III. PROGRAM ADMINISTRATION	12
A. IMPLEMENTATION	12
B. APPEALS	12
C. VARIANCES	13
D. ENFORCEMENT AND PENALTIES	14
A. WATER QUALITY ASSESSMENT	15
B. NEEDS ASSESSMENT, PROBLEM IDENTIFICATION AND PLANNING	15
C. RECORDS	16
D. ANNUAL REPORT	16
IV. APPLICATIONS AND PERMITS	18
A. APPLICATIONS	18
B. WHO CAN REPRESENT THE APPLICANT	19
C. REQUIRED APPLICATION INFORMATION	19
D. SITE EVALUATION	20
E. PLOT PLAN AND SYSTEM DESIGN	21
F. CONSTRUCTION PERMIT ISSUANCE	22
G. CONSTRUCTION PERMIT FINAL APPROVAL	24
H. CONSTRUCTION PERMIT EXTENSION, RENEWAL OR REISSUANCE	25
I. OPERATING PERMITS	25
J. SPECIAL PERMITS	28
V. SITE EVALUATION AND TESTING	30
A. SITE EVALUATION	30
B. SOIL PROFILE TESTING	31
C. PERCOLATION TESTING	32
D. WET WEATHER TESTING	35
E. SLOPE STABILITY	37
VI. OWTS DESIGN AND CONSTRUCTION	38
A. SYSTEM DESIGN TYPES DESCRIBED	38
B. GENERAL DESIGN STANDARDS APPLYING TO ALL OWTS	39
C. GENERAL CONSTRUCTION REQUIREMENTS	41
D. SETBACKS	41
E. DAILY DESIGN FLOW	43
F. APPLICATION RATES	45
G. WASTE STRENGTH	48
H. BUILDING SEWERS	49

I. EFFLUENT SEWER	49
J. SEPTIC TANKS	50
K. PUMP TANKS	52
L. GREASE INTERCEPTORS	52
M. DISPERSAL SYSTEM GOALS	53
N. GRAVITY LEACHING TRENCHES	54
O. PRESSURE DOSED LEACHING TRENCHES	56
P. LEACHING BEDS	59
Q. AT GRADE BEDS	60
R. MOUND SYSTEMS	62
S. DRIP DISPERSAL	64
T. PUMPS, CONTROLS AND ALARMS	65
U. DOSING SIPHONS	66
V. SUPPLEMENTAL TREATMENT UNITS	67
W. CAPPING FILL	69
X. INTERCEPTOR DRAINS	69
Y. ENGINEERED FILLS	70
VII. NON-DISCHARGE SYSTEMS	72
A. EVAPORATIVE BEDS	72
B. HOLDING TANKS	72
C. VAULT TOILETS	77
D. CHEMICAL TOILETS	77
E. COMPOSTING OR INCINERATING TOILETS	79
VIII. OPERATION, MAINTENANCE, & MONITORING	80
A. TIER 0 OWTS	80
B. TIER 1 OWTS	80
C. TIER 2 OWTS	80
D. TIER 3 OWTS	82
E. TIER 4 OWTS	82
F. OWTS PUMPING AND INSPECTION	83
G. COUNTY SERVICE AREA #6	85
IX. OWTS REPAIR, EXPANSION, REPLACEMENT	86
A. FAILED OWTS	86
B. MINOR REPAIRS	86
C. MAJOR REPAIRS, CORRECTION, REPLACEMENT	88
D. RECONSTRUCTION	88
E. EXPANSION OF USE	89
F. CHANGE OF CHARACTER OF USE	90
G. OWTS CERTIFICATION	90
X. LAND DEVELOPMENT	91
A. GENERAL REQUIREMENTS FOR LAND DIVISIONS PROPOSING INDIVIDUAL OWTS	91
B. PRELIMINARY REVIEW	92
C. FORMAL REVIEW	92

October 2016

D. PARCEL SIZE AND PROVISION FOR WATER SUPPLY AND WASTEWATER TREATMENT	94
E. LAND DEVELOPMENT PROJECTS PROPOSING COMMUNITY OWTS	95
F. BOUNDARY LINE ADJUSTMENTS	96
<u>XI. GRAYWATER SYSTEMS</u>	<u>97</u>

I. PURPOSE

These regulations are intended to implement the Amador County Onsite Wastewater Treatment Systems (OWTS) ordinance consistent with the State Water Resources Control Board Policy for Siting, Design, Operation and Management of On-site Wastewater Treatment Systems (Policy). This is a guidance document for installers, service providers, qualified professionals, and the general public to understand Amador County Environmental Health Department (Department) requirements for permit processing, design, construction, alteration, repair, operation and maintenance of OWTS and related structures and operations. This document also guides program management by Department staff. Our goals are to protect and enhance public health and general welfare, the quality of ground and surface water, and the overall quality of the environment within Amador County.

II. DEFINITIONS

1. Approved public entity: A governing body, such as a city, or a special district, whose boundaries include the entirety of a community OWTS parcel and all parcels served by the community OWTS. The approved public entity must include sewer service among the duties it has been authorized to provide by LAFCO.
2. As-built: Actual locations, dimensions, and related information of an OWTS or graywater system after construction or installation. An as-built drawing or statement may be required from the qualified professional or contractor prior to final approval of the construction permit in the event deviation from the approved design is known or suspected.
3. Bedroom: A room that is intended or used as a bedroom shall be considered a bedroom for the purposes of OWTS design. Any room that has a closet (or closet-sized recessed area) and provides the minimum square footage and legal egress required of a bedroom as defined in the California Building Code and which provides a reasonable degree of privacy shall be considered to be a bedroom. A room that was originally designed and constructed for use as a bedroom does not cease to be a bedroom solely because it is used for another purpose
4. Certification: A written statement signed in ink by a qualified professional and bearing their current stamp, regarding an installed OWTS stating his/her opinion regarding the system. Typical certification statements include a declaration that the system complies with identified specifications and/or design criteria, observations of workmanship and materials, and that the system may be expected to function in a sanitary manner for the intended use. Certification of a new installation shall indicate that the OWTS was installed in substantial conformance with the approved design or shall acknowledge any material changes or substitutions of materials or equipment. If any changes or substitutions are determined to be unsuitable, the qualified professional shall make known what changes are necessary to enable certification. Certification shall identify any significant information gaps including inspections not requested or performed. An as built drawing shall be included as part of the certification if the approved design does not accurately reflect the layout of the system as installed. Certification shall not be construed as a guarantee; it is the opinion of a qualified professional based on the available information at the time the opinion is rendered.
5. Chemical toilet: A relatively small water tight receptacle for human wastes which contains chemical additives to reduce odors. Chemical toilets must be pumped or drained on a frequent basis and the wastes disposed at an approved treatment and disposal facility. Chemical toilet purveyors must register annually with the Department.
6. Composting toilet: A type of dry toilet that uses a predominantly aerobic processing system to treat human excreta, by composting or managed aerobic decomposition.

7. Contractor: A person competent in systems installations, and possesses an active Class A, B (when performing multiple phases of construction pursuant to contractor's licensing law), C-42, or C-36 contractor's license in accordance with the provisions of the California Business and Professions Code.
8. Conventional system: An OWTS which employs a septic tank and gravity fed leaching trenches or beds, whether aggregate filled or chambered. A conventional system may include a lift station if the discharge does not pressure dose the dispersal trenches or beds.
9. Design capacity: The maximum long term daily average waste water flow that a sewage disposal system is designed for. For residential applications, design capacity shall be 112.5 gallons per bedroom per day.
10. Design standards: The set of criteria, dimensions, specifications, or other factors adopted and published by the Department which form the basis for approval or denial of an on-site sewage disposal permit.
11. Dispersal field: Also called disposal field, is a system of disposal trenches, beds, or drip line.
12. Disposal trench/leach line: A trench, no greater than three feet wide, with vertical sides and substantially flat bottom with clean, coarse drain rock covered by a siltation barrier and soil cover, containing a single distribution pipe laid the length of the trench. A disposal trench or leach line may be constructed with leaching chambers or other approved media in lieu of drain rock.
13. Distribution box: A structure which receives septic tank effluent and distributes it via gravity to two or more disposal trenches.
14. Dosing tank or chamber: A watertight receptacle placed after a septic tank or other treatment unit equipped with a pump or dosing siphon designed to discharge a known, repeatable volume of effluent, typically under pressure, at each cycle to either the next treatment unit or the disposal field(s).
15. Dwelling: Any structure or building or any portion thereof which is used, intended, or designed to be occupied for human living purposes including, but not limited to, houses, guest houses, mobile homes, travel trailers, hotels, motels, and apartments.
16. Effective soil depth: The depth of suitably permeable soil material above bedrock, excessively permeable gravel, any limiting soil horizon, or seasonal groundwater that provides filtration of effluent.
17. Effluent rated pump: A pump designed and approved to distribute septic tank effluent.
18. Engineer: Civil Engineer Registered with the California Department of Consumer Affairs

19. Engineered OWTS: An OWTS designed by a qualified professional, not necessarily an engineer, that may utilize the components of a conventional system but may modify or supplement those components with one or more special design features, such as filters, pressure distribution, at grade or mound dispersal, that provide additional treatment, transport, or hold the sewage prior to dispersal to the ground, dispersal via evaporation, or hauling.
20. Engineered fill: Soil meeting the criteria specified by a qualified professional, placed pursuant to the qualified professional's design, and tested to demonstrate compliance with conditions necessary to support the design and installation of an OWTS
21. Expansion: An increase in capacity of an OWTS via alteration of the existing system or construction of additional tankage, treatment, or disposal field.
22. Health officer: The health officer of Amador County or a registered environmental health specialist acting on behalf of the health officer of Amador County.
23. Incinerating toilet: A type of dry toilet that uses electric or fuel power to burn wastes rather than flushing with water to a treatment and disposal system.
24. Installer: A contractor, as defined, the owner or person(s) employed by the owner for wages and for whom worker's compensation insurance is provided.
25. Interceptor drain: Also called a curtain drain or French drain, is a subsurface drainage trench intended to intercept and lower or eliminate shallow groundwater in the disposal field to improve site suitability for onsite sewage disposal. Intercepted groundwater flows via gravity to a discharge point at the ground surface some distance from the disposal field. An interceptor drain shall include a water tight membrane on the bottom and downslope sidewall and shall be permeable on the upper surface and upslope sidewall of the collection portion of the drain. An interceptor drain may be required to be installed and proven effective prior to issuance of a permit for new construction. An interceptor drain may be required as a condition of a repair permit.
26. Intermittent sand filter system: An on-site sewage disposal system combining a septic tank, dosing system, a single pass sand filter, and disposal field.
27. Limiting layer: A layer that impedes the vertical movement of water, air, or growth of plant roots.
28. Monitoring port: A man made structure used in association with an OWTS to observe or sample wastewater or groundwater.
29. Perched water table: A subsurface saturated zone that occurs above a relatively impermeable layer. Perched water is separated, to some degree, from one or more lower confined aquifer(s).

30. Percolation rate: The time required for water to permeate through the earth or ground. A percolation rate is expressed in the number of minutes required for water to fall one inch in a percolation hole as determined by standardized test methods established in this document.
31. Performance standards: The set of criteria, dimensions, specifications, or other factors which are to be met during ongoing operation of an on-site sewage disposal permit. Deviation from the performance standards may range from very minor, warranting observation only, to moderate, warranting action to prevent future failure, to major, indicative of failure or imminent failure and demanding immediate corrective action.
32. Permeable soil: Soil that has a measured or estimated percolation rate of 240 minutes per inch or faster.
33. Point of discharge: The point at which effluent enters the soil. For trenches or beds it is the trench or bed bottom, for drip it is the depth at which the drip line is laid, for at grade beds and mounds it is the original earth surface grade. For OWTS constructed on fill the point of discharge may be above the original earth surface grade but no higher than the surface grade of the approved fill.
34. Pressure distribution lateral: Piping and fittings in a pressure distribution system beginning at the manifold which distribute effluent through small diameter orifices to one trench or to one zone of a treatment or disposal bed.
35. Pressure distribution manifold: Piping and fittings in a pressure distribution system which divides the effluent among the trenches or zones to receive effluent.
36. Pressure distribution system: A system designed to uniformly distribute effluent under pressure to the disposal field or treatment unit.
37. Public health hazard: A condition which exposes or threatens to expose humans to biological, chemical, or physical agents or energy which are likely to cause illness, disorders or disability. These include, but are not limited to, pathogenic viruses, bacteria, parasites, and toxic chemicals.
38. Qualified professional: This term shall be as defined, revised or interpreted in the Policy.
39. Repair: To correct, replace, reconstruct or otherwise perform work to make an OWTS functional as necessary to prevent or eliminate a public health hazard or pollution of public waters created by a failing septic system. A repair is intended to serve the originally approved capacity and character of use.
40. Replacement area: An area that is at least equal to 100% the size of the area approved for the initial sewage disposal field, approved by ACEHD, and meets the minimum

applicable requirements. Replacement area may require a different design type than the original design.

41. Septic tank effluent: Partially treated sewage, typically containing minimal solids, which is discharged from a septic tank
42. Sewage: Human wastes, including kitchen, bath, laundry wastes from residences, buildings, industrial establishments, or other places, or any liquid contaminated with materials thereof.
43. Sewer well: Includes any of the following:
 - a. Any hole dug or drilled into the ground and intended for a purpose other than disposal of sewage, such as water well or a mine shaft, when and if the hole has been abandoned for its intended use and is being used for the disposal of sewage.
 - b. Any hole dug or drilled into the ground that is intended to be used for the disposal of sewage and that extends to or into a subterranean water-bearing stratum, which stratum is used, or is suitable for a source of water supply for domestic purposes.
44. Single family dwelling: A dwelling designed for, or occupied exclusively by, one family.
45. Site modification: Construction or alteration based on a design by a qualified professional intended to improve soil characteristics of a proposed dispersal field site such as increasing effective soil depth, improving soil permeability, or lowering the elevation of seasonal groundwater.
46. Slope: The inclination of the ground surface of a given area determined by the difference in elevation of two points divided by the horizontal distance between the point expressed as percent.
47. Soil: This term shall be as defined, revised or interpreted in the Policy.
48. Soil consistence: The resistance of a material to deformation or ruptures. The degree of cohesion or adhesion of the soil mass.
49. Soil horizon: A layer of soil material often approximately parallel to the land surface and differing from adjacent layers in physical, chemical, and biological properties or characteristics such as color, structure, texture, consistence, pH, etc.
50. Soil profile log: A description of the qualities and arrangement of soil horizons beginning at the surface extending downward. Soil profile logs record the observations made by a qualified professional of the soil profile, typically as observed in a backhoe excavation or test pit extending to an obviously restrictive or otherwise unusable horizon. The purpose of the soil profile log is to record depth of apparently permeable soil, estimate permeability of the usable material, observe indicators of seasonal saturation, and to note any other factors that may affect the operation of an on-site sewage disposal system.

51. Test pit: An open pit dug to sufficient size and depth to permit thorough examination of the soil profile to evaluate its suitability for subsurface sewage disposal.
52. Unstable landforms: Areas showing evidence of mass down-slope movement such as debris flow, landslides, rockfalls, and hummocky hillslopes with underdrained depressions upslope.
53. Vault toilet: A large watertight receptacle designed to receive and store human wastes for disposal at another location. Vault toilets typically do not employ the use of chemical additives to reduce odors. Vault toilets must be pumped out on a frequent basis and the wastes disposed at an approved treatment and disposal facility.
54. Vertical separation: The vertical distance between point of discharge and a limiting layer, fractured bedrock, or groundwater.
55. Wet Weather Period: That portion of the year designated by the Department for wet weather determination of soil and groundwater conditions. This begins following the accumulation of sixty (60) percent of the seasonal average annual rainfall and extends until March 15 unless extended by the Department depending on local climatic conditions.
56. Wet Weather Testing: Physical site evaluation during the wet weather period to determine maximum groundwater elevations.

III. PROGRAM ADMINISTRATION

A. Implementation

1. Program implementation shall be the responsibility of the Department. The Amador County Health Officer shall be consulted on an as needed basis to assist in making determinations regarding public health risk, declaration of nuisance, or to advise on development and implementation of local policy. Any changes to these regulations shall be subject to approval by resolution of the Amador County Board of Supervisors. The program, including these regulations, shall be consistent with the requirements of the Policy.
2. The County, its officers, agents and employees are not liable or responsible for damage resulting from the defective construction of any OWTS as herein provided, nor will the County or any official or employee thereof be liable or responsible by reason of any inspection, waiver, approval, denial or compliance directive authorized hereunder.

B. Appeals

1. Any staff level decision or interpretation may be appealed. The initial appeal should be to the Director and may be informal or in writing. The appeal should be made within 15 days and identify the requirement, denial, or cost which is at issue and state the desired outcome or proposed alternatives. Within 15 days of receipt, the Director may grant or deny the appeal provided the decision does not conflict with Amador County Code. There is no cost associated with an initial appeal.
2. Anyone not satisfied with the decision of the Director may make a second level appeal to the Land Use and Community Development Committee (Committee). Such appeal should be made in writing within 15 days of the result of an appeal to the Director. The appeal should state the specific requirement, denial, or cost which is at issue and include the desired outcome or proposed alternatives. An appeal fee, established by County Code Chapter 7.42, is due at the time the appeal is submitted. Any request for waiver of the appeal fee should be in writing and made at the time the appeal is submitted. The Committee may consider the appeal at their next regular meeting. The Committee may direct staff, take the matter under advisement for future action, or they may forward the appeal to the Board of Supervisors.
3. Third level appeals to the Board of Supervisors shall comply with Chapter 2.92, Amador County Code.

C. Variances

1. Any request to deviate from policies and procedures established by the Department or to deviate from the requirements of these regulations shall be submitted to the Director. The variance request should be specific, stating the standard and the specific deviation or alternative proposed. The decision of the Director may be appealed to the Board of Supervisors pursuant to Chapter 2.92, Amador County Code.
2. Any request to deviate from Amador County Code must be processed by the Board of Supervisors pursuant to Chapter 2.100, Amador County Code. Decisions of the Director may be appealed to the Amador County Board of Supervisors.
3. Where it is not possible or feasible to meet one or more compliance points established in Chapter 14.12, the applicant shall apply to the Amador County Board of Supervisors for a variance.
4. Pursuant to Section 9.4 of the OWTS Policy, the following OWTS are not to allowed to be authorized in a Local Agency Management Program (LAMP) if the OWTS:
 - a. Include a cesspool
 - b. Receive a projected flow over 10,000 gallons per day
 - c. Include any transport or treatment features that expose wastewater to the surface of the ground or which discharge effluent on or above the post installation ground surface such as via sprinklers, exposed drip lines, free-surface wetlands, or a pond
 - d. Be located on slopes greater than 30 percent without a slope stability report prepared by an appropriately registered professional
 - e. Include leaching area for IAPMO certified dispersal systems using a multiplier less than 0.70 to reduce the size of the dispersal field
 - f. Include supplemental treatment without requirements for periodic monitoring or inspections.
 - g. Receive significant amounts of wastes dumped from RV holding tanks.
 - h. Create separation between the point of discharge and groundwater of less than two (2) feet, except for seepage pits, which shall not be less than 10 feet.
 - i. Serve structures located within 200 feet from any public sewer to which the structure may lawfully and feasibly connect unless the connection fees and construction cost are greater than twice the total cost of the replacement OWTS and the Department determines that the discharge from the OWTS will not affect groundwater or surface water to a degree that makes it unfit for drinking or other uses.
5. Any variance which could result in issuing an installation or repair permit for an OWTS within 1,200 feet of an intake point for a surface water treatment plant for

drinking water, in the drainage area catchment in which the intake point is located, and located such that it may impact water quality at the intake point such as upstream of the intake point for a flowing water body, or if the OWTS would be within a horizontal sanitary setback from a public well, or where the OWTS would be located within a reduced setback to a private water supply or which may infringe upon the property rights of others shall not be granted unless the parties potentially affected have been advised of the variance request in writing and afforded the opportunity to object or attend hearings consistent with the notification requirements of the Brown Act.

D. Enforcement and Penalties

1. If the Director determines that a person has committed, or is committing, a violation of any law, regulation, permit condition, order, or other requirement that the Director is authorized to enforce or implement pursuant to Chapter 14.12, Amador County Code, or these regulations, the director may take one or more enforcement actions as necessary to abate or prevent pollution or nuisance conditions. Where possible, education and direction shall be the preferred methods of gaining compliance.
2. If necessary, the Director may
 - a. Issue a notice of violation
 - b. Issue a cease and desist order
 - c. Issue a cleanup and abatement order
 - d. Refer the case to the Code Enforcement Department for appropriate legal action
 - e. In consultation with the Code Enforcement Department, refer the case to other affected agencies
3. Any person violating the provisions of Chapter 14.12 or these regulations shall be liable for all investigation, abatement and enforcement costs incurred by the County.
4. If it is determined by the Director that a person knowingly violated Chapter 14.12 or these regulations in order to avoid costs, penalty fee(s) authorized by Chapter 7.42 shall apply in addition to any other applicable fees or cost recovery.
5. A violation of any provision of this chapter or regulations adopted pursuant to this chapter which constitutes a public nuisance is subject to abatement in accordance with law.

IV. PROGRAM OVERSIGHT AND REPORTING

A. Water Quality Assessment

1. The program shall include a water quality assessment component to determine the general operation status of OWTS and evaluates the impact of OWTS discharges as well as other potentially contaminating activities, and assess the extent to which groundwater and local surface water quality may be adversely impacted. At a minimum, the assessment program shall gather data on nitrate and pathogen content of the waters sampled. The water quality assessment program shall take into consideration those factors and conditions listed in section 9.1.1 through 9.1.12 of the Policy. Water quality data shall be gathered from existing sampling programs including but not necessarily limited to new well construction sampling, sampling required as part of an existing discharge MRP for WDR or NPDES, sampling conducted by public water systems, and monitoring performed by watershed management groups.

B. Needs Assessment, Problem Identification and Planning

1. Areas of focus for water quality assessment include:
 - a. High elevation recreational lakes such as Silver Lake, Lake Kirkwood and Lower Bear River Reservoir. These high quality water bodies are the surrounded by resorts, campgrounds and clusters of small lots with seasonal cabins within their respective basins. Soil conditions are sometimes marginal or poor for OWTS. Many existing systems predate adopted design standards. The Department shall gather available surface water quality data collected from these water bodies and groundwater data from the area which may be influenced.
 - b. Streams such as Jackson Creek and Sutter Creek with numerous OWTS in close proximity predating adopted design standards and which may not adhere to established stream setbacks. In some cases soil conditions are marginal or poor for OWTS. The Department shall gather available surface water quality data collected from these water bodies.
 - c. Subdivisions approved in the 1960s and 1970s such as Lake Camanche Village, Silver Lake Pines, and Willow Creek Ranch Estates. Lots are often undersized by current standards, effective soil depth is often shallow over limiting layers and shallow perched groundwater is not uncommon. New construction and replacement OWTS in these subdivisions often require site modification, supplemental treatment and/or mound dispersal to compensate for site constraints. The Department shall gather available groundwater quality data

collected from water wells in these areas.

- d. Communities such as Drytown and Volcano which rely on OWTS, have relatively small average lot size, many OWTS predating adopted design standards, and may not adhere to currently established setbacks.
- e. Areas subject to a basin plan prohibition on OWTS, Amador City, Amador County (Adopted by Regional Water Board Order No. 73-129; effective as of 12/15/72) and the Martell Area, Amador County (73-129; 12/15/72). Both prohibitions were established in association with funding for sanitary sewer projects, the Amador City sewer and the Martell sewer. Whereas the Amador City prohibition is coterminous with the city limits, the Martell Area is an arbitrary six square mile block, a good portion of which will not be served by sanitary sewer in the foreseeable future. A number of OWTS exist within this area (despite the prohibition) and there are occasional queries about new construction.
- e. Large and community OWTS in which wastewater application is focused on a relatively small footprint.

C. Records

1. The Department shall retain permanent records of all permitting actions and monitoring reports and will make those records available within 10 working days upon written request for review by a Regional Water Board. The records for each permit shall reference the Tier under which the permit was issued. Currently the Department maintains paper records.

D. Annual Report

1. Each year, no later than February 1, the department shall submit a report to the Regional Board which includes a spreadsheet of the number, location, and description of permits issued for OWTS where a variance is granted. The report must also identify the tier of each new or replacement permit, as that term is defined in the Policy.
2. The annual report shall include the number and location of complaints pertaining to OWTS operation and maintenance, and identification of those that were investigated and how they were resolved. The report shall identify the applications and registrations issued as part of the local septic tank cleaning registration program pursuant to Section 117400 et seq. of the California Health and Safety Code (HSC).
3. The annual report shall include data collected by the water quality assessment program. The results shall be identified as representing ground or surface water

quality, which of the areas of focus identified in these regulations they represent, or if representative of water quality in general. Where possible, GPS information shall be recorded locating the sample sites.

4. Every fifth year the report shall include evaluation of the monitoring program and an assessment of whether water quality is being impacted by OWTS, identifying any changes in the LAMP that will be undertaken to address impacts from OWTS. The evaluation shall consider whether any water quality impacts may be linked to other structures or activities such as municipal, institutional or industrial waste discharges, sanitary sewer overflows, impacts related to wildlife or livestock, storm water runoff, flooding or similar disaster conditions.

IV. APPLICATIONS AND PERMITS

A. Applications

1. Applications shall be made on forms provided by the Department.
2. The applicant is responsible for the accuracy and completeness of all information provided.
3. The Department is responsible for communicating with the applicant regarding processing of the application and permit. The applicant shall be responsible for relaying that information to interested parties.
4. The applicant shall be responsible for securing the services of appropriately licensed contractors, qualified professionals, operation and maintenance service providers or other such services, information or supplies which may be necessary to process the application.
5. After review by the Department, the applicant shall be referred to the Central Valley Regional Water Quality Control Board (Regional Board) for a discharge which will:
 - a. Include a cesspool
 - b. Receive a projected flow over 10,000 gallons per day
 - c. Include any transport or treatment features that expose wastewater to the surface of the ground or which discharge effluent on or above the post installation ground surface such as via sprinklers, exposed drip lines, free-surface wetlands, or a pond
 - d. Be located on slopes greater than 30 percent without a slope stability report prepared by an appropriately registered professional
 - e. Include leaching area for IAPMO certified dispersal systems using a multiplier less than 0.70 to reduce the size of the dispersal field
 - f. Include supplemental treatment without requirements for periodic monitoring or inspections.
 - g. Receive significant amounts of wastes dumped from RV holding tanks.
 - h. Create separation between the point of discharge and groundwater of less than two (2) feet, except for seepage pits, which shall not be less than 10 feet.
 - i. Serve structures located within 200 feet from any public sewer to which the structure may lawfully and feasibly connect unless the connection fees and construction cost are greater than twice the total cost of the replacement OWTS and the Department determines that the discharge from the OWTS will not affect groundwater or surface water to a degree that makes it unfit for drinking or other uses.

B. Who Can Represent the Applicant

1. Application for OWTS construction permits shall be made by the owner of the property or the owner's authorized agent on forms provided by the Department.
2. The owner's authorized agent may be:
 - a. A licensed real estate agent under contract with the owner,
 - b. An appropriately licensed contractor under contract with the owner
 - c. A qualified professional under contract with the owner, or
 - d. Any other person with power of attorney for the owner.
3. The applicant shall be the owner or authorized agent identified on the application.

C. Required Application Information

1. An application may be rejected if found to be incomplete or inaccurate. The application must include the owner's name, mailing address, and phone number. The application must include the Assessor's parcel number, parcel size, and the source of potable water.
2. The application must be signed by the applicant. If the applicant is other than the owner, the applicant's mailing address and phone number shall be included with the application.
3. The application must include a plot plan, minimum size 11" X 17" reasonably to scale, showing:
 - a. All existing or proposed structures
 - b. All existing or proposed grading
 - c. All water bodies or drainages on or within 200 feet of the property
 - d. All easements
 - e. Roads on or adjacent to the property
 - f. A north arrow
 - g. Wells on or within 200 feet of the property
 - h. Any other pertinent information that is likely to have bearing on the construction or operation of the OWTS
4. The application must include the physical address (if any) and a vicinity map or directions to the property from the nearest intersection of county maintained roads.
5. The application shall include the number and type structures to be served by the disposal system. If residential, the application shall state the number of bedrooms intended to be served.

6. Where a sanitary sewer exists within 200 feet or any portion of the existing or proposed drainage system connecting, written documentation indicating why the structure cannot lawfully and feasibly connect to the sanitary sewer.
7. If the application is for repair or replacement as a result of a mortgage inspection, a copy of that inspection report shall accompany the application.
8. The application may be rejected if incomplete, inaccurate or unless applicable fee(s) have been paid.

D. Site Evaluation

1. Upon determination by the Department that the application is complete, the applicant may schedule a site evaluation with the Department. It is the responsibility of the applicant to arrange for a knowledgeable person to meet the Department representative at the site evaluation to locate property boundaries, underground utilities, preferred building site, etc.
2. Unless it has been determined by the Department that sufficient soil information exists in the record, it is the responsibility of the applicant to arrange for suitable equipment and a qualified equipment operator to excavate soil profile test pits at the time of the site evaluation.
3. Upon completion of the site evaluation, the Department shall either prepare a permit for the construction of a conventional system for residential use, notify the applicant in writing if additional information or testing is needed, or refer the applicant to a qualified professional for design or further evaluation.
4. The applicant may submit a report or design prepared by a qualified professional for review by the Department at the time the application is filed or at any time thereafter. The report or design shall be accompanied by the appropriate review fee as established by Amador County Code Chapter 7.42. The Department will perform a site visit to determine if the report or design provides all necessary information in order to issue a permit.
5. Within 30 days of receipt of a report or design from a qualified professional, the Department shall either prepare a permit for issuance or notify the applicant and the qualified professional in writing if additional information or testing is needed.

E. Plot Plan and System Design

1. Due to site conditions, proposed character of use or other limitations, there is no guarantee that an OWTS construction permit will be issued for each and every application filed.
 - a. If site conditions are compatible with conventional OWTS siting and design criteria and if the proposed character of use is residential, serving one to four dwelling units located on the same legal parcel, the Department shall prepare a permit for issuance based upon the plot plan submitted.
 - b. If site conditions are not compatible with conventional OWTS siting and design criteria or if the proposed character of use is other than described in the above paragraph, the applicant shall be directed to retain the services of a qualified professional for further testing and design development. The Department may, under limited circumstances, prepare a conventional permit for those non-residential uses which do not produce high strength waste and where the daily design flow is predictable and fairly limited.
 - c. Designs submitted by a qualified professional shall at a minimum, comply with the following:
 - i. Accuracy – All mapping of OWTS areas shall be sufficiently accurate to allow for adequate design, plan review and construction. The minimum accuracy is plus or minus one (1) foot horizontal location and plus or minus one tenth (0.1) foot vertical location. For large parcels [over five (5) acres], less accurate mapping is acceptable for the entire parcel provided more detailed mapping is provided in the immediate area of the building(s) and OWTS.
 - ii. Basis of Plans – While every effort should be made to locate four recorded monuments, a minimum of at least two (2) recorded monuments shall be used as a basis for plan preparation (all recorded monuments shall be designated as being found or not found on the plans). Where no recorded survey monuments associated with the parcel exist, the design shall describe what information has been used as the basis of the plans.
 - iii. Scale – For parcels less than three-fourths (3/4) acres in size the scale shall be one (1) inch equals ten (10) feet and for all larger parcels the scale may be either one (1) inch equals ten (10) or twenty (20) feet. Minimum map size shall be 11" X 14". Maps sized 24" X 36" are preferred
 - iv. Contour Interval – Sufficient field survey data shall be taken for the accurate plotting of existing contour lines as follows:
 - a. For plans with a one inch equals ten feet (1" = 10') scale and an average slope of less than ten (10) percent, and plans with a one inch equals twenty feet (1" = 20') scale and an average

- slope less than five (5) percent the contour interval shall be two (2) feet.
- b. Otherwise, the contour interval may be five (5) feet or two (2) feet.
 - v. All bench mark location(s) and all established reference points must be accurately noted.
 - vi. Indicate the location of each of the following which are located on the property or within the distances specified outside of the property lines:
 - Swale 25 feet
 - drainage course 50 feet
 - Private water supply well 100 feet
 - Public water supply well 150 feet
 - Pond, lake or reservoir* 200 feet
 - Flowing stream or river* 100 feet

*Distance to be measured from the high water mark.
 - vii. Plans shall indicate the location of property lines, all profile test pits and percolation tests, easements, proposed wastewater disposal area including expansion area, trees greater than twelve (12) inches in diameter located in the proposed disposal areas, proposed building locations, driveways, edge of paved road(s), and cut banks and fill banks with vertical height noted in one (1) foot increments.
 - viii. The design shall include any other surface features on the property or on nearby property which may affect the siting, design or operation of the OWTS.
 - ix. A minimum of three full sets of drawings, calculations and supporting data shall be submitted.
 - x. Every OWTS designed by a qualified professional which includes one or more treatment units, involves drip dispersal, is a large OWTS or is a community OWTS shall include the required operation and maintenance (O&M) program and shall state the qualifications, if any, of the person performing the O&M.

F. Construction Permit Issuance

1. The Department shall not issue an OWTS construction permit except in response to a duly filed application as set forth in this chapter and only when the applicant has complied with all other requirements for such sewage application permit as set forth in County Code and this publication. Due to site conditions, there is no guarantee that a disposal system permit shall be issued once an application has been submitted.

2. No OWTS shall be constructed except in accordance with the required construction permit issued by the Department. Construction shall not substantially deviate from the dimensions, location, or other details of the permit without prior approval of the Department. If the permit is issued based on an approved design by a qualified professional, there shall be no deviation from the permit without prior approval of both the qualified professional and the Department.
3. The Department strongly recommends that the installer be experienced and qualified in the construction of the type OWTS to be constructed. Errors due to misunderstanding the design principles and best practices may be irreparable and lead to substantially higher cost to the owner. With proper coaching an owner-builder can sometimes produce satisfactory results in the construction of a simple conventional OWTS. More complex systems should be attempted only by experienced and knowledgeable appropriately licensed contractors.
3. The Department shall not issue an OWTS construction permit unless applicable fees have been paid.
4. When more than one OWTS is to be installed on the same property, a separate construction permit is required for each system.
6. Where the OWTS is intended to serve a new or expanded use subject to a building permit, the OWTS construction permit shall be issued prior to issuance of the building permit and shall obtain final approval prior to final approval of the building permit.
7. Where an OWTS is intended to serve more than one parcel, an approved public entity shall be identified and documentation provided indicating that the entity intends to accept and operate the OWTS. The approved public entity shall be copied all correspondence and shall be involved in plan review, approval and construction inspections.
8. The Department may alter, suspend or revoke any on-site sewage disposal construction permit if it is determined that the permit was issued based on erroneous information or that completion or use of the OWTS constructed under the permit would result in nuisance conditions or pollution, would adversely impact the rights of others, or for similar cause. The permittee shall be notified in writing of such alteration, suspension or revocation and provided the opportunity to appeal any adverse decision.

G. Construction Permit Final Approval

1. No construction permit shall receive final approval unless the Department has either inspected the construction of the system pursuant to the construction inspection schedule or has waived one or more inspections.
2. No construction permit for an OWTS which requires an operating permit issued by the Department shall receive final approval unless the operating permit has been executed.
3. No construction permit for an OWTS designed by a qualified professional shall receive final approval unless the designer has certified that the OWTS was installed in substantial conformance with the approved design or has acknowledged any material changes or substitutions of materials or equipment. Certification shall identify any significant information gaps including inspections not requested or performed. An as built drawing shall be included as part of the certification if the approved design does not accurately reflect the layout of the system as installed. If the qualified professional objects to any changes or substitutions, the permit shall not receive final approval until the objection has been resolved.
4. Where certification by the designer is not feasible and the Department is aware of no construction defects, deficiencies, or factors which would otherwise prevent final approval of the permit, the owner may sign an acknowledgement prepared by the Department stating that they understand the reason(s) why certification by the designer is not feasible and that they are aware that without such certification there may be no recourse in the event design defects are discovered. Final approval of the permit shall be granted on this basis.
5. Upon final approval of any construction permit, the Department shall assure that the permittee has been provided a copy of the OWTS design, any as built information, care and maintenance instructions, and where applicable a copy of the operating permit. The permittee shall also receive information regarding service providers they may contact to ensure maintenance, repair, or replacement of critical items within 48 hours of failure. This contact information will also be placed on the Department's website.
6. No construction permit for a community OWTS shall receive final approval unless an approved public entity has accepted the OWTS in writing.

H. Construction Permit Extension, Renewal or Reissuance

1. Upon request of the permittee or the installer prior to expiration, a construction permit may be extended one time for a period of ninety (90) days at no cost for the purposes of completing construction or any other tasks necessary for final approval of the permit.
2. Upon written request by the permittee for renewal of the construction permit while the permit is still valid and payment of the permit renewal fee, the Department shall review the proposed disposal site and the OWTS design to confirm that conditions comply with criteria in effect at the time the permit would have expired. If the OWTS is designed by a qualified professional, the request for renewal must include confirmation by the designer that the existing design remains valid. If the site and the design are compliant, the permit shall be renewed for a period of one year from the expiration date. If not compliant, the Department shall advise the owner of the reason(s) the permit cannot be renewed.
3. If a construction permit has expired, an owner may submit to the Department a new construction application, request re-issuance of the expired construction permit, and pay the appropriate fee. If the OWTS is designed by a qualified professional, the request for reissuance must include confirmation by the designer that the existing design remains valid. The Department shall review the proposed disposal site and the OWTS design to confirm that conditions comply with criteria currently in effect. If compliant, the permit shall be re-issued for a period of one year. If not compliant, the Department shall advise the owner of the reason(s) the permit cannot be re-issued.

I. Operating Permits

1. An operating permit shall be in the form of a recordable agreement between the owner of record and the Director, signing on behalf of the County. The operating permit shall, at a minimum, describe the conditions which place the OWTS at greater risk of failure or contamination in the event of neglect or abuse, the conditions of the operating permit, duties of the operator, disclosure that the property is enrolled in County Service Area #6 (CSA 6), and provide for ongoing monitoring by the Department.
2. Unless the operating permit conditions specify other criteria, each OWTS subject to an operating permit shall be inspected annually by the Department. At the time of inspection, observation shall be made for signs of failure or stress of the dispersal system, groundwater separation, or signs of physical damage or

- conflicting use. Visual evaluation of effluent quality for those systems including supplemental treatment shall be performed. Electrical and mechanical features shall be exercised to verify functionality and waste flows to the OWTS shall be noted. If present, the owner or user of the OWTS shall be interviewed regarding significant events or problems with the system and to answer questions they may have. A monitoring report shall be sent to the permit holder including any recommendations or requirements resulting from the monitoring inspection.
3. The Department shall require an operating permit under the following circumstances:
 - a. New or replacement OWTS that do not comply with effective soil depth and groundwater separation requirements for conventional or modified conventional designs whether or not the OWTS includes supplemental treatment.
 - c. New or replacement OWTS constructed pursuant to a special permit for temporary repair or replacement of a conventional dispersal field where soil conditions are not compatible with standards established by these regulations.
 - d. Any new or replacement OWTS which includes a holding tank or evaporative bed.
 - e. Any new or replacement OWTS which includes a vault toilet other than a vault toilet operated by a state or federal agency on state or federal lands.
 - f. Any situation in which a graywater system is installed to temporarily relieve the stress on a failed OWTS until a replacement OWTS is designed and installed.
 - g. Any OWTS serving a retail food facility that includes treatment to reduce fats, oil and grease (FOG) which does not comply with the grease interceptor standard established by these regulations or where the designer of the system or the agency operating the community OWTS serving the structure requires an operation and maintenance program for the treatment unit.
 - h. The Department shall require an operating permit for any new or replacement large OWTS.
 - i. The Department shall require an operating permit for any new or replacement community OWTS.
 - j. The Department shall require an operating permit for any existing OWTS which successfully petition for a transfer of regulatory oversight from the Regional Board to the County.
 4. Other than community OWTS, the property served by any OWTS that requires an operating permit shall be enrolled in CSA #6 and shall be subject to periodic monitoring and inspection by the Department. Assessment is levied through CSA #6 to fund the program. Assessments rates shall be reviewed and adjusted, if necessary, no less frequently than once every three years. Assessment rates shall

be established by ordinance and codified in Chapter 7.42, Amador County Code.

5. The property upon which a community OWTS dispersal field is located shall be enrolled in CSA #6 and shall be subject to periodic monitoring and inspection with prior written notice by the Department.
6. Prior to monitoring OWTS which are not associated with other activities permitted by the Department, the owner or their designee shall be contacted in advance and given the opportunity to schedule an appointment. OWTS serving facilities subject to other permits issued by the Department shall, to the extent feasible, be monitored concurrent with routine facility inspections.
7. Where an operating permit is required, the agreement must be returned to the Department bearing the notarized signature of the owner prior to issuance of the construction permit for a new construction project and prior to final approval of a construction permit for a repair or replacement OWTS. The Director shall sign on behalf of the County and the department shall cause the document to be recorded prior to final approval of any construction permit and a copy of the recorded agreement shall be provided to the owner. The owner shall assure that a copy of the operating permit is provided to the OWTS operator, if separate from the owner, or any other interested parties.
8. An owner who leases the property served by an OWTS subject to an operating permit to another person shall be ultimately responsible for compliance with the terms and conditions of that permit.
9. Operating permits which are not conditioned to terminate upon change of ownership or a predetermined date shall remain in continuous force and effect unless expunged, revised, suspended or revoked by the Department.
 - a. Expungement shall be in the form of a subsequent recorded document which negates the operating permit and would be appropriate if connection is made to a sanitary sewer or to an OWTS which does not require an operating permit.
 - b. Revision shall be in the form of a subsequent recorded document which replaces the existing operating permit with a new document containing new information reflecting a change in the OWTS or the use(s) served by the OWTS.
 - c. Suspension of the operating permit shall be in writing to the permittee and shall advise of the reason(s) for suspension, the actions needed to reinstate the permit and the time frame for these actions.
10. Permit revocation shall be appropriate only if there is no known manner in which the OWTS can reasonably be expected to function in a safe and sanitary manner and no feasible repair or replacement is known that would sufficiently remedy the

deficiency.

- a. Permit revocation shall be pursued through the Amador County Code Enforcement Department or the equivalent if within any city.
- b. No less than 15 days prior to the proposed date of permit revocation, a Notice of Intent to Revoke the Operating Permit shall be served upon the permittee.
- c. The Building Official shall be copied the Notice of Intent to advise of substandard sanitation due to the lack of connection to a functional sewage disposal system.
- d. The permittee shall have the right to a hearing pursuant to Chapter 2.06, Amador County Code or the equivalent process provided by applicable city codes.
- e. Permit revocation shall be in the form of a subsequent recorded document which negates the operating permit and describes the constraints and conditions which cause the OWTS not to function properly and make repair or replacement infeasible.

J. Special Permits

1. A special permit shall only be issued in situations where the strict application of chapter 14.12 and these regulations is impossible, impractical or unnecessary and the special permit would be consistent with the goals of the program. A special construction permit is appropriate where any variance to the siting and design criteria of chapter 14.12 or these regulations is granted. Special permits may include conditions, time limits, or require the issuance of an operating permit and ongoing monitoring. It shall be the responsibility of the permittee to transmit a copy of the special permit to subsequent owners in interest.
2. No special permit shall be issued which violates the prohibitions outlined in Section 9.4, et seq, of the Policy.
3. A special permit may be issued to enable construction of a minor dispersal field expansion to temporarily abate a failure until design of the full repair or replacement is complete or weather is appropriate for construction of the full repair/replacement.
4. A special permit may be issued for a repair or replacement OWTS which consumes available replacement area and for which any future repair or replacement would involve construction within the same footprint as the active OWTS.
5. Special permits are appropriate in conjunction with an operating permit and enrollment in CSA #6 in the following situations:

- a. Temporary expansion or replacement of a conventional dispersal field where soil conditions are not compatible with standards established by these regulations but where the existing system has provided suitable service for a reasonable amount of time, has not been linked to water quality impacts, at least 5 feet of vertical separation is provided between the dispersal field bottom and seasonally high groundwater, and the OWTS otherwise poses no significant risk to water quality, public health and the environment.
- b. Any situation in which a graywater system is installed to temporarily relieve the stress on a failed OWTS until a replacement OWTS is designed and installed.
- c. For replacement OWTS that do not meet the Policy established horizontal separation requirements, the replacement OWTS shall meet the horizontal separation to the greatest extent practicable. In such case, the replacement OWTS shall utilize supplemental treatment and other mitigation measures, unless the Department finds that there is no indication that the previous system is adversely affecting the public water source, and there is limited potential that the replacement system could impact the water source based on topography, soil depth, soil texture, and groundwater separation. e. For new OWTS, installed on parcels of record existing at the time of the effective date of this Policy, that cannot meet the above horizontal separation requirements, the OWTS shall meet the horizontal separation to the greatest extent practicable and shall utilize supplemental treatment for pathogens as specified in sections 10.9 and 10.10 of the Policy and any other mitigation measures prescribed by the Department.

V. SITE EVALUATION AND TESTING

A. Site Evaluation

1. Prior to issuing a construction permit, the Department shall perform a site evaluation. Site evaluation is required to determine siting constraints, setbacks, soil conditions, and other factors that play a role in the design and operation of the OWTS. The proposed OWTS dispersal site must contain sufficient soil with suitable characteristics to support the OWTS. Effective soil depth free of seasonal saturation or limiting horizons, apparent permeability whether based on soil texture and structure or perc testing, site slope, contour, vegetation, area available, and proposed character of use combine to determine the capabilities of the site.
2. The applicant or a knowledgeable representative shall be present during the site evaluation to assist in locating property boundaries, easements, utilities including private water lines, etc. as they related to OWTS siting and design.
3. Where existing file information or the proposed character of use indicates the OWTS will not be conventional, the Department may advise the applicant to retain the services of a qualified professional to participate in the site evaluation.
4. For replacement of a septic tank or similar construction that does not affect the dispersal field, no soil profile testing shall be required as part of the evaluation. An application to construct, expand, repair or replace a dispersal field normally requires soil profile tests. If sufficient information is on file to support the proposal, the Department shall not require additional testing.
5. Activities, conditions and structures, whether existing or planned, in the vicinity of the proposed OWTS construction site shall also be considered to determine how these may impact the design and operation of the OWTS. The site must be reasonably protected from impacts due to grading, focused surface water flow, vehicle traffic, construction activities, etc.
6. Site modification to create a suitable OWTS dispersal site where no such site exists may be pursued by retaining the services of a qualified professional to propose a design for the modification for review and approval by the Department. Once approved, the modification may be constructed by the applicant and the site shall undergo confirmation testing to demonstrate that the site is now suitable to support the desired OWTS.
7. If site evaluation indicates conditions are compatible with a conventional OWTS and if the application is to serve a residential use of one – four dwelling units

located on a single parcel, the Department shall prepare a permit for issuance. If the site is not compatible with conventional design criteria or if the proposed use is other than residential or comparable to residential, the Department shall notify the applicant of the need to retain the services of a qualified professional for additional testing and/or design of the OWTS.

B. Soil Profile Testing

1. Unless it has been determined by the Department that sufficient data already exists, soil profile tests shall be performed for every application to construct a dispersal field including any expansion, repair or replacement. It shall be the responsibility of the applicant to arrange for excavation equipment and operator at the time of the site evaluation.
2. Soil profile testing shall be performed by a qualified professional employed by the Department or the private sector. Where any question exists regarding a soil profile report, the Department retains the right to require observation of soil profile test pits by qualified Department staff to confirm the information provided. It shall be the responsibility of the applicant to represent all property boundaries, easements, and underground utilities or other underground structures.
3. Soil profile testing allows direct observation of soil horizons in pits excavated in the proposed disposal area. This evaluation estimates soil capacity for grain-to-grain flow of water; observes for mottled, gleyed or dull soil colors which may evidence seasonal saturation; and checks for restrictive horizons or signs of open channel flow of water to groundwater. In addition to soil color, vegetation, slope and contour shall also be considered when reviewing for potential indicators of seasonally shallow groundwater. Historic documentation of similar or nearby sites will also be considered.
4. Soil profile test pits shall be excavated at the time of the site evaluation. The applicant shall be responsible for arranging for the appropriate equipment and equipment operator to safely and efficiently excavate test pits. The applicant shall ensure that underground utilities or other sensitive features are identified and avoided during soil profile testing.
5. Profile test pits shall be at least two feet in width and shall be excavated to a depth of at least 8 feet unless obvious refusal is encountered, excavation is stopped short by the Department representative or qualified professional, or unless additional depth is required to support a deeper dispersal field. When requested by the Department representative, the test pits shall be constructed with a ramp no steeper than 30% slope to a depth of four feet. No Department staff member shall

enter an excavation deeper than 4 feet. No test pit deeper than 4 feet shall be left open and unattended.

6. The number of test pits required will vary depending on conditions encountered and the nature of the proposed project. As a rule, establishing designated disposal sites for a land division requires more tests than confirming soil conditions for a replacement OWTS on an existing developed parcel. More tests shall be required where significant variation is noted from one test to the next than would be the case where each test reveals very similar conditions. More tests shall be required where soil conditions are very marginal as opposed where conditions are obviously compatible with conventional OWTS siting and design criteria. More tests shall be required to support a community OWTS than for a single family residential design. Department staff shall exercise judgement based on familiarity with soil conditions typical of the area and past performance of area OWTS in addition to on site observations.
7. Soil texture and consistence shall be logged using the USDA soil classification system. Permeability is estimated based this information and may be supplemented by other sources such as published soil survey data and/or perc test results in similar soil series and sites.
8. Where possible, GPS shall be used to log UTM coordinates of test pit locations. Locations shall be sketched on the plot plan.

C. Percolation Testing

1. Percolation testing shall be performed by a qualified professional in the designated disposal area for every new parcel proposed to be created relying on OWTS.
2. Unless waived by the Department, percolation testing shall be required for every OWTS design prepared by a qualified professional except those instances in which effluent is not discharged to the soil.
3. In any case in which soil permeability is in question, percolation testing by a qualified professional may be required by the Department.
4. Percolation testing is used as a tool for site evaluation and not necessarily as an absolute rule for justifying the suitability of an area. Modification of the percolation testing depth or procedures may be required in unusual circumstances.

5. Where percolation testing is required to support the creation of a new residential parcel or to support a single family residential OWTS or similarly sized design on an existing parcel of record, a minimum of six percolation tests must be performed.
6. Additional testing shall be required in support of large OWTS, community OWTS, land divisions in which the proposed OWTS will not comply with siting criteria for conventional or modified conventional OWTS or when the results of the initial testing indicate highly variable percolation rates or rates that clearly conflict with the soil profile or other available data.
7. Dimensions
 - a. Percolation test holes shall be eight (8) inches in diameter. As near as the actual soil conditions permit, the sidewalls of the test hole shall be vertical and the bottom shall be horizontal.
 - b. The depth of a percolation test hole shall be measured from a straight edge placed parallel to the slope of the ground over the center of the hole to the bottom of the hole.
 - c. The minimum average hole depth shall be equal to or greater than the maximum disposal system trench depth, measured from the greatest trench sidewall depth. The number of holes deeper than the trench bottom depth shall be equal to or greater than the number of holes shallower than the trench bottom depth. To support designs that do not include trenches, perc tests shall be performed consistent with design-specific criteria.
 - d. The minimum depth of an actual test hole placed in the bottom of a larger hole, such as a backhoe cut, shall be twelve (12) inches.
 - e. Percolation tests to support shallow, pressure dosed trenches shall include at least two tests at 24 inches deeper than the design trench depth to demonstrate soil permeability is 240 mpi or faster.
8. Hole Preparation - The bottom and sides of the test hole shall be scarified to remove smears and areas of compacted soil only to the extent which replicates actual trench construction. All loose material shall be removed from the test hole. Either a four (4) inch or six (6) inch diameter perforated pipe shall be centered in the hole and surrounded by pea gravel to a minimum depth of twelve (12) inches.
9. Presoak - A minimum water depth of twelve (12) inches shall be maintained in the test holes for a minimum of four (4) hours, between twelve (12) and twenty-four (24) hours prior to testing. Where expansive soils are known or suspected, a presoak of 24 – 48 hours shall be conducted. A reservoir and float valve may be needed for an extended presoak.

10. Percolation Test Apparatus - Water level readings shall be made using a separate fixed flotation device for each hole.
11. Test Procedure
 - a. Notify the Department at least 24 hours prior to presoak or test.
 - b. The test hole shall be filled / adjusted to a water depth of between six (6) inches and eight (8) inches above the bottom of the hole. Water level readings shall generally be taken and recorded at thirty (30) minute intervals for four (4) hours or until three successive readings vary by no more than one-sixteenth (1/16) of an inch. A minimum of three readings shall be taken. The water level shall be adjusted whenever a reading indicates that the water level is less than six (6) inches above the bottom of the hole.
 - c. The time interval between measurements may be adjusted to be shorter for faster percolation rates or longer for slower rates to allow the water depth to be maintained between six (6) inches and eight (8) inches above the bottom of the hole.
12. Rate Calculation - The percolation rate is calculated for each test hole by dividing the time interval used between measurements by the magnitude of the smallest of the final three successive readings of water level drop. The calculated results for a percolation rate shall be expressed in terms of minutes per inch (mpi). The percolation rate for the site is the arithmetic mean of the percolation rates of all tests representing trench bottom conditions.
13. Reporting - The report shall include:
 - a. Owner's name, APN, and street address
 - b. Date of test and date and duration of presoak
 - c. Name of person performing the perc test
 - d. Soil texture – sand, loam clay, other
 - e. Method used to dig holes (hand or power auger)
 - f. Unusual conditions
 - g. Report hole depths to the nearest inch
 - h. Report rates in minutes per inch (mpi)
 - i. Locate all tests on plot plan
 - j. Submit raw data for all holes tested including drops between readings and times
 - k. Signature and registration number of the qualified professional responsible for the report.

D. Wet Weather Testing

1. Unless waived by the Department, wet weather testing shall be performed in the designated disposal area for every new parcel proposed to be created relying on OWTS.
2. Where new construction or expansion is proposed on an existing parcel of record and indicators of potential high groundwater are observed, including but not necessarily limited to unusually dark or mottled soils, water loving vegetation, topography, or other factors, wet weather testing shall be performed to support the OWTS design.
3. Determination of depth to seasonal groundwater for repair or replacement OWTS shall be based on the indicators mentioned above or other readily available data.
4. A qualified professional is not necessary to perform wet weather testing. An applicant may complete and submit a request for wet weather testing to the Department and pay the appropriate fee. The applicant shall construct at least three wet weather monitoring pipes within the proposed disposal area. The Department will perform monitoring throughout the next qualifying wet weather season until the season is over. The shallowest depth to groundwater noted during this monitoring will be the controlling criteria for disposal system design.
5. The locations, depths, and number of excavations or groundwater monitoring pipes shall be determined by the Department at the time of construction. Depth, the dimension shown as "X" on the figure below, shall enable observation to a minimum of five feet below the deepest portion of any conventional or modified conventional dispersal field to be proposed, a minimum of two feet below the deepest portion of any dispersal field for effluent receiving supplemental treatment, or a minimum of two feet below the surface where a mound or at-grade disposal bed are to be proposed. It is generally safer to extend the monitoring pipe deeper than the absolute minimum.
6. Monitoring pipes shall be installed in the proposed initial and replacement leach field areas. The pipe(s) shall extend approximately 6 inches into, but in no event through, a restrictive horizon.
7. Wet weather testing may begin when the seasonal rainfall total, following July 1, is 60% of annual average for the area. In areas where there is insufficient rainfall information, the Department shall use information from surrounding areas to determine the start date for monitoring. Wet weather testing may continue through the wet season until rainfall decreases significantly, typically March 15. Depending on weather patterns this date may be extended at the discretion of the Department.

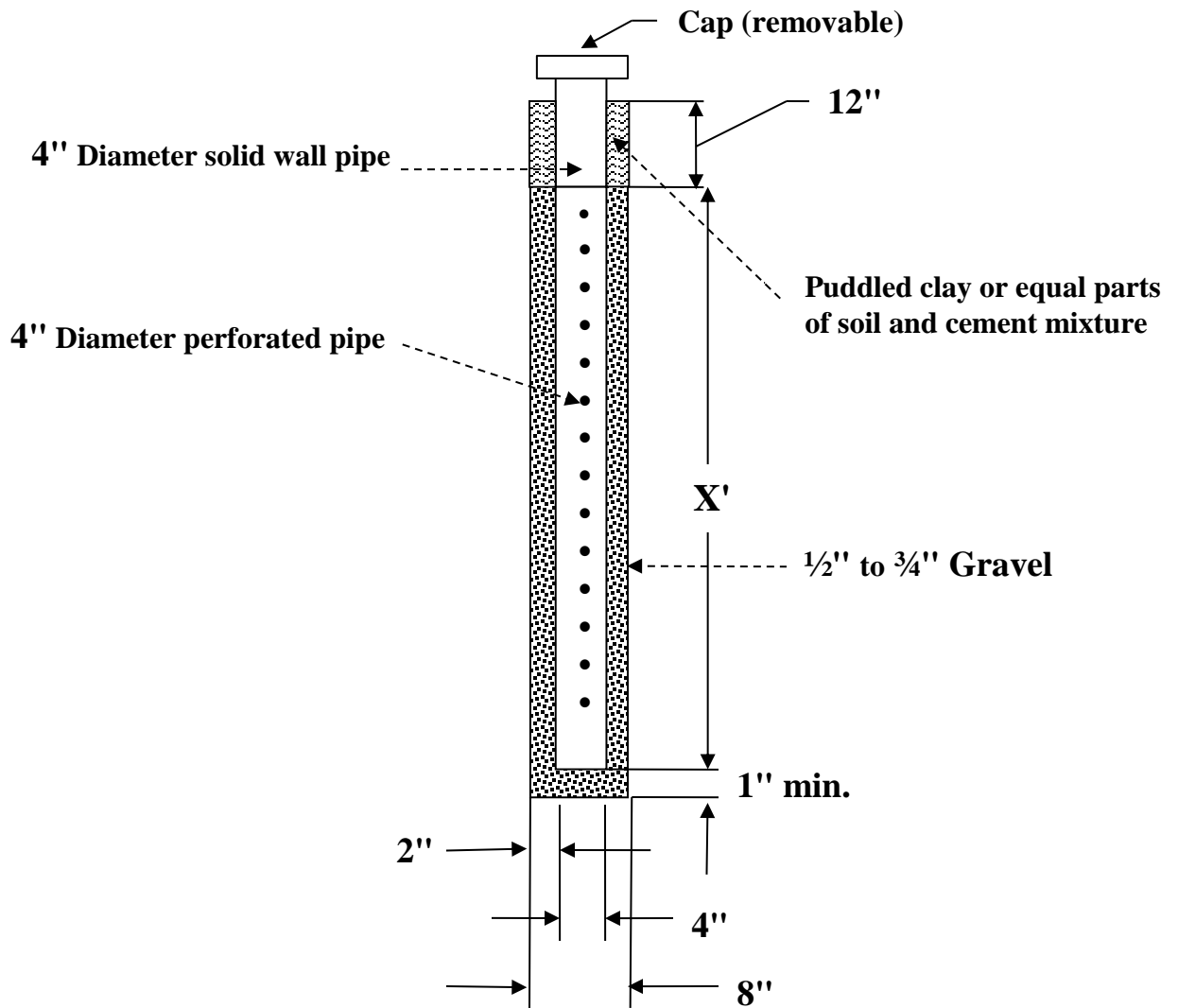

8. At elevations where snow covers the ground throughout much of the winter, testing shall not begin until there has been adequate snow melt to observe the ground surface and charge any perched groundwater bearing horizons.
9. Groundwater may sometimes be diverted away from an area by the use of an interceptor drain. A complete set of engineered plans from a qualified consultant must be presented to and approved by the Department prior to construction of an interceptor drain. After construction of the drain, wet weather testing must document that the depth to groundwater in the proposed leach field and replacement areas have been lowered sufficiently to support the anticipated OWTS design.

E. Slope Stability

1. Slope stability analysis shall be performed by an appropriately licensed professional if any portion of the proposed OWTS would be located on a slope in excess of 30%.
2. If during the site evaluation, the Department observes signs indicative of unstable landforms such as unconsolidated fill, significant erosion rills, tension cracks, evidence of prior earth movement or slides, and leaning or “pistol butt” trees, the Department shall require a slope stability assessment prepared by an appropriately licensed professional.
3. The assessment shall result in a written report, signed and stamped by the professional, submitted to the Department for review prior to issuance of the OWTS construction permit. The report shall provide a professional opinion regarding whether the proposed project would increase the risk of slope failure, creep or other movement which could damage the OWTS or endanger life or property. The report shall recommend any appropriate construction methods and/or erosion control measures to minimize any risk. The report shall include the data, calculations and assumptions used in formulating the opinion and any recommendations. The OWTS design shall incorporate the recommendations of the assessment report. The report shall be required prior to issuance of a construction permit for the OWTS which it supports

VI. OWTS DESIGN AND CONSTRUCTION

A. System Design Types Described

1. Conventional systems – Sometimes referred to as standard systems, these include a septic tank and one or more leaching trenches to which effluent is distributed via gravity. On rare occasions a leaching bed may be employed instead of trenches. Where the dispersal field is at a higher elevation than the source of the sewage, a pump station or lift station may be included to elevate the septic tank effluent to the gravity fed dispersal field. OWTS designed by the Department are conventional systems. Some OWTS designed by qualified professionals are conventional systems. Conventional systems may include simple effluent filters but do not include supplemental treatment. The dispersal field for a conventional OWTS is constructed within native soil at depths typically ranging from two to five feet, depending on effective soil depth, slope and other conditions.
2. Modified conventional system – These systems are designed by qualified professionals and are sometimes called special design, pressure dosed or engineered systems. These OWTS include a pump or siphon to deliver effluent to the dispersal field in predetermined volumes and/or intervals to evenly distribute septic tank effluent and enable absorption and to encourage aerobic conditions within the field. Dispersal fields are often relatively shallow, often with capping fill required over the field area to provide at least 12” minimum soil cover over aggregate or leaching chambers or similar structures. These systems may include FOG treatment but OWTS that include supplemental treatment to compensate for site soil constraints are categorized differently. Any large OWTS or community OWTS that do not include supplemental treatment, would be considered modified conventional designs.
3. Alternative systems – Any system which includes mitigation for sites in which five feet of separation between seasonally high groundwater and point of discharge cannot be assured is considered alternative. These include mounds, OWTS incorporating supplemental treatment, and non-discharge systems.
4. Non-discharge system – Any OWTS that does not discharge waste to the ground on-site is considered a non-discharge system. Holding tanks, vault toilets, and evaporative beds are various types of non-discharge systems.
5. Cesspools, sewer wells and similar structures are prohibited.

B. General Design Standards Applying to All OWTS

1. No property shall be developed in excess of its capacity to properly absorb sewage effluent whether by initial construction or expanded use. The size of the lot on which the OWTS is to be constructed shall be sufficient to permit proper location, installation and operation. The average daily amount of sewage, the character of the soil, and the source of water supply will determine the necessary lot size. The minimum lot size must be sufficient for compliance with all setback requirements and for one hundred percent disposal area expansion or replacement.
2. Where a repair or replacement OWTS is to be constructed and one hundred percent disposal area expansion or replacement no longer exists as a result, the construction permit shall be considered a special permit and a copy of that permit provided by the owner to interested parties, such as prospective buyers, to provide constructive notice of the status of the OWTS. Unless required for any other reason, no operating permit shall be required solely because replacement area is insufficient.
3. Where a repair or replacement OWTS is to be constructed and the minimum area normally required for the dispersal field is not available and, as a result, the dispersal field provide 70% or less of the normally required application area, the permit shall be considered a special permit and an operating permit shall be required as a condition of the special permit. The operating permit shall provide constructive notice to interested parties of the status of the OWTS and enroll the system in CSA 6 for ongoing monitoring.
4. Any construction permit issued for an OWTS intended to serve a residential use of 20 or more persons or a daily design flow of 1,500 gallons or more shall, prior to final approval of the construction permit, require the issuance of an operating permit and the parcel shall be enrolled in CSA #6.
5. Any construction permit issued for an OWTS intended to serve structures or uses on two or more separate legal parcels shall be considered a community OWTS and shall be accepted and operated by an approved public entity. These community OWTS shall require an operating permit and shall be enrolled in CSA #6. If the public entity is not the applicant, the applicant shall provide a letter of commitment from the public entity indicating the willingness to accept, operate and maintain the community OWTS in compliance with the required operating permit. The installer shall provide the public entity notice satisfactory to that public entity of all construction inspections.
6. Provision is required for any construction permit issued for an OWTS that will be located entirely or in part on a separate legal parcel from the parcel containing the structure served.

- a. It must be demonstrated to the satisfaction of the Department that locating the OWTS, including 100% replacement area, on the same parcel as the structure served is not the best solution. Insufficient area free of sanitary setbacks is one valid reason to pursue such a project. The availability of a site on adjoining property with soil conditions that are inherently lower risk is another valid reason.
 - b. It is preferred by the Department that a boundary line adjustment or merger of the parcels be performed so that the resulting configuration will locate OWTS and the structure served on the same parcel.
 - c. If boundary line adjustment or merger are not feasible, an easement shall be recorded to advise interested parties and provide permanent right to use the off-site area including access for maintenance and repair.
 - d. If the parcels are under the same ownership, an easement cannot be recorded but a recorded document that accomplishes the same practical effect as an easement shall be required.
 - e. Where such provision must be made for a new construction project, it shall be completed prior to issuance of the construction permit.
 - f. In the event of repair, expansion or replacement OWTS, the provision shall be made prior to final approval of the construction permit.
 - g. If the parcels are not merged, the Department may require proof that the ability of the subservient parcel to provide adequate area with conditions suitable for an OWTS, including 100% replacement area, will not be substantially diminished by the project.
7. No person shall connect to an OWTS any dwelling, structure, or other units if the total projected sewage flow generated would be greater than that allowed under the original OWTS construction permit unless the capacity and condition of the OWTS has been assessed and certified by a qualified professional to be adequate for the proposed use and that certification has been reviewed and approved by the Department.
 8. No person shall connect to an OWTS any dwelling, structure or other units if the character of use is likely to generate a higher waste strength than that allowed under the original OWTS construction permit unless the treatment capability and condition of the OWTS has been assessed and certified by a qualified professional to be able to provide suitable treatment of the intended waste stream and that certification has been reviewed and approved by the Department.
 9. Every OWTS construction or repair that disturbs the soil shall incorporate erosion control measures for all disturbed areas. Unless otherwise specified, erosion control shall consist of at least 5 lbs of annual grass seed and 20 lbs of fertilizer (16-20-0) per 1,000 square feet and loose straw to a depth of 2 – 4 inches. Minimal irrigation to germinate the seed is recommended or delay planting until rain is in the forecast.

C. General Construction Requirements

1. No OWTS dispersal field shall be constructed when soil moisture is excessive. If the soil forms a ribbon or wire when worked with the hands it is too wet. The Department and the designer (if any) must agree that the site is ready before construction may begin.
2. No significant changes shall be made to the OWTS without authorization from the Department and designer (if any).
3. Keep equipment and foot traffic out or off of the trench bottom or bed to minimize soil compaction.
4. All pipes, tanks, and treatment units shall be supported by undisturbed native soil or fill which has been tested for appropriate compaction. Sand or road base should be used for bedding where angular rock is present. Backfill must receive sufficient jetting or compaction to minimize settling and damage to pipe alignment or exposure of portions of the system.
5. Trenches and beds shall be excavated to the depth and grade specified. Fill shall not be placed into an over-excavated area unless an exception is made for unavoidable tree removal.

D. Setbacks

1. The minimum horizontal setback requirements for construction of an OWTS shall be as follows:

OWTS Component	Setback to	Distance
Septic Tank	Structure ^a	5 feet
Septic Tank	Property Line	5 feet ^b
Septic Tank	Private Water Well	100 feet
Septic Tank	Public Water Well	150 feet
Septic Tank	Dispersal Field	5 feet
Septic Tank	Private Water Line	5 feet
Septic Tank	Public Water Line	10 feet
Septic Tank	Swale	25 feet
Septic Tank	Drainage Course	50 feet from centerline or edge of eroded channel
Septic Tank	Perennial Stream	100 feet from edge of normal high water flow

Septic Tank	Pond, Lake or Canal	200 feet from high water level
Septic Tank	Water Supply Reservoir or Canal	200 to 400 feet from the high water line ^d
Septic Tank	Distribution Box	5 feet
Dispersal Field	Structure ^a	10 feet
Dispersal Field	Property Line	10 feet ^b
Dispersal Field	Private Water Well	100 feet
Dispersal Field	Public Water Well	150 feet ^c
Dispersal Field	Private Water Line	5 feet
Dispersal Field	Public Water Line	10 feet
Dispersal Field	Swale	25 feet
Dispersal Field	Drainage Course	50 feet from centerline or edge of eroded channel
Dispersal Field	Perennial Stream	100 feet from edge of normal high water flow
Dispersal Field	Pond, Lake or Canal	200 feet from high water level
Dispersal Field	Water Supply Reservoir or Canal	200 to 400 feet from the high water line ^d
Dispersal Field	Cut Bank	4:1 setback from top of cut
Dispersal Field	Private Utility Trench	5 feet
Dispersal Field	Distribution Box	5 feet

Footnotes:

- a. Structure includes any footing, foundation, driveway or hard surface.
- b. Must also be clear of any conflicting easement, whether public or private. The property line setback on parcels created after October 1987 which are served by individual wells shall be 50 feet.
- c. Where the dispersal system is greater than 10' in depth, then the setback must be greater than 200' from public water supply well. Where the dispersal system is greater than 20' in depth, and less than 600' from public water supply well, then the setback must be greater than the distance for two-year travel time of microbiological contaminants, as determined by qualified professional. In no case shall the setback be less than 200'.
- d. Where the effluent dispersal system is within 1,200 feet from a public water system's surface water intake point, within the catchment of the drainage, and located such that it may impact water quality at the intake point such as upstream of the intake point for flowing water bodies, the dispersal system shall be no less than 400 feet from the high water mark of the reservoir, lake or flowing water body. Where the effluent dispersal system is located more than 1,200 feet but less than 2,500 feet from a public water systems' surface water intake point, within the catchment area of the drainage, and located such that it may impact water quality at the intake point such as upstream of the intake point for flowing water bodies, the dispersal system shall be no less than 200 feet from the high water mark of the reservoir, lake or flowing water body. For replacement

OWTS that do not meet these horizontal separation requirements, the replacement OWTS shall meet the horizontal separation to the greatest extent practicable. In such case, the replacement OWTS shall utilize supplemental treatment and other mitigation measures, unless the Department finds that there is no indication that the previous system is adversely affecting the public water source, and there is limited potential that the replacement system could impact the water source based on topography, soil depth, soil texture, and groundwater separation. For new OWTS, installed on parcels of record existing at the time of the effective date of these regulations, that cannot meet the above horizontal separation requirements, the OWTS shall meet the horizontal separation to the greatest extent practicable and shall utilize supplemental treatment for pathogens so that effluent from the supplemental treatment components does not exceed a 30-day average TSS of 30 mg/L and shall further achieve an effluent fecal coliform bacteria concentration less than or equal to 200 Most Probable Number (MPN) per 100 ml. In both instances the owner of the affected public water system shall be notified.

2. Large or community OWTS may be required to provide greater setbacks if design analysis indicates this is necessary to protect public health and the environment.

E. Daily Design Flow

1. Daily design flows for single family residential units and multi-family structures up to and including four connected dwelling units shall be based on the number of bedrooms, with an assumed flow of 112.5 gallons per bedroom.
2. Designs for OWTS that treat domestic strength wastewater and that are not large or community OWTS may be based on hydraulic flows. Designs for large or community OWTS or any OWTS which treats high strength waste shall include analysis and justification of organic and nutrient loading in addition to hydraulic loading.
3. OWTS serving uses other than single family through four unit residential structures shall be sized using the estimated waste flow rates based on type of occupancy as provided in the State Plumbing Code for private sewage disposal systems. The Department will review and consider other data, particularly where the intended use differs from the typical use assumed by that source.
4. Estimated wastewater flows for any design which are based on average measured historic flows for the particular operation or measured average flows of similar operations shall include a safety factor equal to at least 50% in sizing tanks,

- treatment units and the dispersal field as a precaution against failure linked to peak events, growth, or unusual characteristics of the particular operation.
5. Every OWTS that is subject to an operating permit shall include a means to measure wastewater flow through the system. Cycle counters or meters measuring effluent discharged from the system are two examples that may be used.
 6. Except where specifically allowed by a variance, special permit, or this document, each OWTS shall have adequate capacity to properly treat and dispose of the maximum projected daily sewage flow. No basement, or surface drainage, or regeneration discharge from a water softener shall be permitted to enter any part of the system.
 - a. OWTS designed to serve structures, such as churches, that are typified by predictable peak uses followed by periods of low or no use may be designed such that peak flows are contained and metered out to the dispersal field over period of low usage, thereby reducing the size of the dispersal field or other components.
 - b. OWTS serving tasting rooms shall assume a design flow no less than 3 gallons per day per guest and shall assume a minimum of 25 guests per day in addition to waste flows generated by employees or other uses served by the system.
 - c. Facilities hosting infrequent (no more than 12 times per year/four times per month) large (more than 125 persons) public events may supplement OWTS capacity and provide for suitable water closets through the use of chemical toilets. Facilities hosting large public events on a more frequent basis shall require permanently constructed facilities and OWTS capacity.
 7. For all new single-family dwellings that may be occupied full time, an OWTS sized to serve at least three bedrooms shall be permitted and installed. If the residence contains more than three bedrooms, the OWTS shall be sized accordingly.
 8. Repair or replacement OWTS for a full time residence shall be sized to serve at least two bedrooms. If the residence contains more than two bedrooms, the OWTS shall be sized accordingly.
 9. Guest houses or similar residential accessory structures that are not approved for full time occupancy and that connect to the OWTS serving the main dwelling shall be considered as one or more additional bedrooms, depending on floor plan, for the purpose of sizing the OWTS.
 10. Second dwelling units served by the same OWTS serving the primary residence shall, where feasible, be provided a separate septic tank and the dispersal field shall be sized based on the total bedroom count.

12. Unconditioned space, structures not compliant with the Building Code requirements for bedrooms, and structures with no plumbing shall not be counted as bedrooms.
13. Flows to community OWTS serving multiple residential connections may be based on a sliding scale ranging from 450 gallons per dwelling unit per day for small systems through 200 gallons per dwelling per day for systems serving 50 equivalent dwelling units per the formula:
 $\#Dwelling\ Units \times 190 + 520 = \text{Community OWTS Design Flow Volume in Gal/Day}$

Design Flow For Community OWTS Based on Number of Dwellings										
2	900		14	3180		26	5460		38	7740
3	1090		15	3370		27	5650		39	7930
4	1280		16	3560		28	5840		40	8120
5	1470		17	3750		29	6030		41	8310
6	1660		18	3940		30	6220		42	8500
7	1850		19	4130		31	6410		43	8690
8	2040		20	4320		32	6600		44	8880
9	2230		21	4510		33	6790		45	9070
10	2420		22	4700		34	6980		46	9260
11	2610		23	4890		35	7170		47	9450
12	2800		24	5080		36	7360		48	9640
13	2990		25	5270		37	7550		49	9830
									50	10000

F. Application Rates

1. Where the Department determines via the site evaluation that conditions are compatible with a conventional system and where the character of use is residential, not exceeding four dwelling units, the department shall approve a conventional OWTS.
 - a. Where soil texture is sand, loamy sand, sandy loam, sandy clay loam, or loam, and structure is not massive or platy, a minimum standard leach field shall be approved. The minimum standard shall provide at least 192 square feet of absorption area per bedroom.
 - b. Where soil texture is, silt loam or silt, and structure is not massive or platy, a minimum standard leach field shall be approved. The minimum standard shall provide at least 225 square feet of absorption area per bedroom.

- c. Where soil texture is clay loam or silty clay loam, and structure is not massive or platy, conventional leaching trenches shall be approved providing a minimum of 285 square feet of absorption area per bedroom.
- 2. Application rates for OWTS which do not include supplemental treatment shall not exceed 0.8 gal/sf/day.
- 3. Where the Department determines via the site evaluation that conditions are compatible with a conventional system and where soil texture analysis indicates an application rate below 0.45 gal/sf/day, the OWTS shall be pressure dosed. If percolation testing is performed and indicates an application rate of 0.45 gal/sf/day or higher, pressure dosing shall not be required.
- 4. Where the Department determines via the site evaluation that conditions are compatible with a conventional system and where soil texture analysis indicates an application rate of 0.2 gal/sf/day or less, supplemental treatment shall be required. If percolation testing is performed and indicates an application rate higher than 0.2 gal/sf/day is appropriate, supplemental treatment shall not be required.
- 5. Where percolation testing is not required or is waived by the Department for OWTS other than conventional residential designs, the application rate based on soil texture shall be as follows:

USDA Texture	Application Rate (Gal/Day/SF)
Sand, Loamy Sand	0.8
Sandy Loam	0.7
Sandy Clay Loam, Loam	0.6
Silt Loam, Silt	0.5
Clay Loam, Silty Clay Loam	0.3
Sandy Clay, Silty Clay, Clay	0.2

- 6. Where application rates are based on the average of perc tests performed at the design depth, the design shall comply with the following curve and table.

APPLICATION RATE (AR) BASED ON AVERAGE PERC RATE (MPI)										
MPI	AR		MPI	AR		MPI	AR		MPI	AR
0	1.00		48	0.53		96	0.28		144	0.15
1	0.99		49	0.53		97	0.28		145	0.15
2	0.97		50	0.52		98	0.28		146	0.15
3	0.96		51	0.51		99	0.27		147	0.15
4	0.95		52	0.51		100	0.27		148	0.14
5	0.94		53	0.50		101	0.27		149	0.14
6	0.92		54	0.49		102	0.26		150	0.14
7	0.91		55	0.49		103	0.26		151	0.14
8	0.90		56	0.48		104	0.26		152	0.14
9	0.89		57	0.47		105	0.25		153	0.13
10	0.88		58	0.47		106	0.25		154	0.13
11	0.87		59	0.46		107	0.25		155	0.13
12	0.85		60	0.45		108	0.24		156	0.13
13	0.84		61	0.45		109	0.24		157	0.13
14	0.83		62	0.44		110	0.24		158	0.13
15	0.82		63	0.44		111	0.23		159	0.12
16	0.81		64	0.43		112	0.23		160	0.12
17	0.80		65	0.43		113	0.23		161	0.12
18	0.79		66	0.42		114	0.22		162	0.12
19	0.78		67	0.41		115	0.22		163	0.12
20	0.77		68	0.41		116	0.22		164	0.12
21	0.76		69	0.40		117	0.22		165	0.11
22	0.75		70	0.40		118	0.21		166	0.11
23	0.74		71	0.39		119	0.21		167	0.11
24	0.73		72	0.39		120	0.21		168	0.11
25	0.72		73	0.38		121	0.20		169	0.11
26	0.71		74	0.38		122	0.20		170	0.11
27	0.70		75	0.37		123	0.20		171	0.11
28	0.69		76	0.37		124	0.20		172	0.10
29	0.68		77	0.36		125	0.19		173	0.10
30	0.67		78	0.36		126	0.19		174	0.10
31	0.67		79	0.35		127	0.19		175	0.10
32	0.66		80	0.35		128	0.19		176	0.10
33	0.65		81	0.35		129	0.18		177	0.10
34	0.64		82	0.34		130	0.18		178	0.10
35	0.63		83	0.34		131	0.18		179	0.10
36	0.62		84	0.33		132	0.18		180	0.09
37	0.62		85	0.33		133	0.17		181	0.09
38	0.61		86	0.32		134	0.17		182	0.09
39	0.60		87	0.32		135	0.17		183	0.09
40	0.59		88	0.31		136	0.17		184	0.09
41	0.58		89	0.31		137	0.17		185	0.09
42	0.58		90	0.31		138	0.16		186	0.09
43	0.57		91	0.30		139	0.16		187	0.09
44	0.56		92	0.30		140	0.16		188	0.08
45	0.55		93	0.29		141	0.16		189	0.08
46	0.55		94	0.29		142	0.15		190	0.08
47	0.54		95	0.29		143	0.15		191	0.08

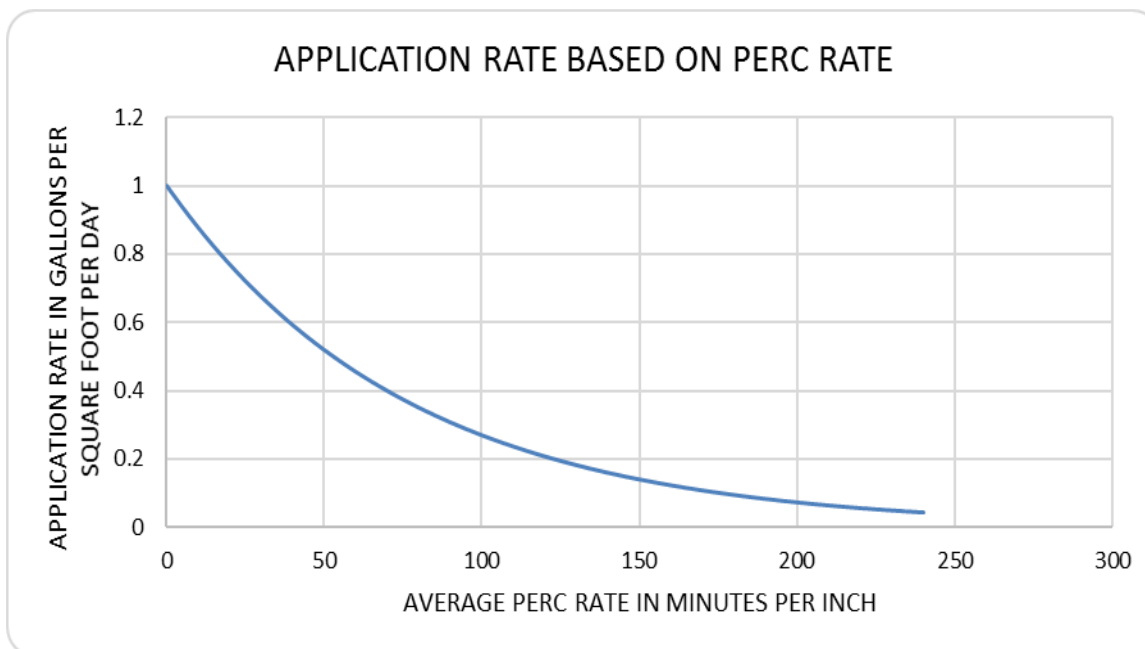

G. Waste Strength

1. Wastewater generated by a residence or multi-family structure is presumed to be domestic strength, having a 30-day average concentration of biochemical oxygen demand (BOD) less than or equal to 300 milligrams per-liter (mg/L) or of total suspended solids (TSS) less than or equal to 330 mg/L or a fats, oil, and grease (FOG) concentration less than or equal to 100 mg/L prior to the septic tank or other OWTS treatment component. Wastewater generated by non-residential uses that meet these criteria shall be considered domestic strength waste.
2. A retail food facility that involves food preparation may reasonably be expected to generate high strength waste, having a 30-day average concentration of biochemical oxygen demand (BOD) greater than 300 milligrams per-liter (mg/L) or of total suspended solids (TSS) greater than 330 mg/L or a concentration of fats, oil, and grease (FOG) greater than 100 mg/L prior to the septic tank or other OWTS treatment component.
3. High strength waste shall, at a minimum, require the inclusion of pretreatment to reduce FOG in the OWTS design. The design shall also analyze the efficacy of treatment units and potential impacts of high strength waste on the dispersal field and the environment. Where treatment units require a level of maintenance significantly different than normal operation of a similarly sized OWTS receiving domestic strength waste, an operating permit shall be required by the Department.

H. Building Sewers

1. The building sewer shall be at least equal diameter to the building drain, shall be ABS approved for use as sewer pipe or PVC approved for use as drain, waste and vent pipe, and shall be constructed in compliance with the installation standards of the current State Plumbing Code. All joints shall be water tight.
2. Building sewer pipe shall be protected from freezing and physical damage by a minimum 12 inch soil cover.
3. Installation in areas subject to vehicular traffic or other potentially damaging activities shall bed the pipe in fines and shall provide a minimum of 24 inches of compacted backfill over the pipe. Where infeasible due to grade, a ductile iron sleeve may be used to protect the pipe from damage or other methods may be approved by the Department on a case by case basis.
4. Minimum grade shall be $\frac{1}{4}$ inch per foot (2%). Where approved by the Department, grade may be reduced to $\frac{1}{8}$ inch per foot (1%) with the use of minimum 4 inch diameter pipe. There is no maximum allowable slope for the building sewer.
5. The building sewer shall be constructed so as to avoid abrupt changes in grade or direction.
6. An accessible cleanout shall be located near the connection between the building drain and the building sewer. Additional building sewer cleanouts shall be installed at intervals not to exceed one-hundred (100) feet in straight runs and for each aggregate horizontal change in direction exceeding one-hundred and thirty-five (135) degrees. Required building sewer cleanouts shall be extended to grade and shall comply with the appropriate sections of Chapter 7 of the California Plumbing Code for sizing, construction, and materials.

I. Effluent Sewer

1. The effluent sewer, from the septic tank to the dispersal field, dosing tank or chamber, or treatment unit, shall be at least equal diameter to the building sewer, shall be ABS, PVC, styrene, or coex pipe, and constructed with watertight joints.
2. The effluent sewer pipe shall be protected from freezing and physical damage by a minimum 12 inch soil cover.

3. Installation in areas subject to vehicular traffic or other potentially damaging activities shall bed the pipe in fines and shall provide a minimum of 24 inches of compacted backfill over the pipe. Where infeasible due to grade, a ductile iron sleeve may be used to protect the pipe from damage or other methods may be approved by the Department on a case by case basis.
4. No minimum grade is required for the effluent sewer but it must be constructed so as to drain freely from the septic tank to the outfall without low spots.

J. Septic Tanks

1. Septic tanks for residential use shall be sized based on the number of bedrooms served.
 - a. One, two or three bedrooms 1,000 gallons
 - b. Four bedrooms 1,200 gallons
 - c. Five or six bedrooms 1,500 gallons
 - d. Add 150 gallons capacity for each bedroom above six
2. Septic tanks serving other uses shall be sized based on daily design flow.
For flows up to 1,500 gallons per day, the tank size shall be at least
$$\text{Tank size} = \text{daily design flow} \times 1.5$$
For flows above 1,500 gallons per day the tank shall be at least
$$\text{Tanks size} = \text{daily design flow} \times 0.75 + 1125$$
3. OWTS serving multi-family structures containing two through four units that may be occupied full time shall, where feasible, provide a separate septic tank for each dwelling unit and the dispersal field shall be sized based on the total bedroom count.
4. The size of the existing septic tank for any expansion, repair or replacement OWTS must be compatible with the number of bedrooms served. An undersized tank shall be replaced as part of the construction permit. An exception to this requirement shall be made where the structure served contains no more than two bedrooms and the existing septic tank:
 - a. Is not constructed of wood or metal,
 - b. Provides at least 750 gallons capacity,
 - c. Is a two compartment design,
 - d. Is water tight,
 - e. Was installed under permit if a permit was required at the time,
 - f. In good condition, and
 - g. Met sanitary setbacks in effect at the time it was installed.

5. All prefabricated septic tanks shall comply with IAPMO Z1000-2007 and shall be designed and constructed in compliance with septic tank construction requirements in the current California Plumbing Code.
6. If other than concrete precast or site built, tanks shall be IAPMO approved.
7. All concrete precast tanks shall be monolithic design.
8. Inlet and outlet sanitary tees, 4 inches in size, are required.
9. Plans for all septic tanks shall be prepared by a registered professional engineer and be reviewed and approved by the Department. Such plans shall show all dimensions, reinforcing, structural calculations, and such other pertinent data as required.
10. The construction of site built septic tanks shall be inspected by the tank design engineer. The design engineer shall certify to the Department that the tank was constructed in substantial compliance with approved plans.
11. Septic tanks shall be constructed of solid durable materials not subject to excessive corrosion or decay and shall be watertight. Approved materials include but are not necessarily limited to, concrete, fiber-reinforced polyester (FRP), and thermoplastic. Wood or steel tanks are not approved.
12. In areas subject to flooding or seasonally high groundwater, all tanks shall be designed or anchored to counter buoyant forces during conditions of the design flood. All piping penetrations, seams and access risers shall be water tight. Water tight testing of installations in areas subject to flooding or high groundwater shall be performed by the installer and witnessed by the department.
13. Tanks which do not meet sanitary setbacks and are installed pursuant to a variance shall be water tight tested. In order to be demonstrated water tight, the tank(s) shall be filled to at least six inches above any seam or penetration and the entire outer surface, except for the tank bottom, shall be exposed for direct visual inspection by the Department. If direct inspection of the tank is not feasible, two inspections shall be made 24 hours apart to note any water loss. If the water level drops by more than $\frac{1}{4}$ inch the tank(s) shall not be considered water tight.
14. Tanks installed under concrete or blacktop paving shall have the required

manholes accessible by extending the manhole openings to grade and shall be provided with lids that are locked or may only be removed by the use of tools.

15. Tanks installed in areas subject to vehicular traffic shall be provided risers and lids as described above. Tanks, risers and lids located in traffic areas shall be designed to withstand anticipated loads by a registered professional engineer.

K. Pump Tanks

1. Every OWTS which includes a pump to transport or dose septic tank effluent shall be provided a pump tank separate from the two compartment septic tank.
2. Pump tanks for residential use shall be sized to allow for at least one day emergency storage capacity above the “alarm on” elevation before effluent rises to the bottom of the inlet invert. Non-residential tanks shall be provided sufficient emergency storage to provide ample time for the user(s) to take corrective action prior to sewage surfacing or impeding sanitary drainage from the building.
3. Inlet tees for pump tanks shall terminate below the lowest normal operating liquid level.
4. The design and construction of pump tanks shall be consistent with the load bearing requirements, approved materials, buoyancy and water tight testing required for septic tanks.
5. Pump tanks shall provide access to the pump assembly via a minimum 24 inch diameter gas tight riser and lid that is locked or may only be removed by the use of tools.
6. Pump tanks shall be accorded the same sanitary setbacks as septic tanks.

L. Grease Interceptors

1. The OWTS serving any retail food facility that prepares food shall include a grease interceptor.
2. Grease interceptors shall be designed in accordance with criteria for gravity grease interceptors as established by Chapter 10 of the current California Plumbing Code.
3. The design and construction of gravity grease interceptors shall be consistent with the load bearing requirements, approved materials, buoyancy and water tight testing required for septic tanks.

4. The minimum size for a gravity grease interceptor shall be 1,000 gallons.
5. Where installation of a 1,000 gallon minimum gravity grease interceptor outside the structure is not possible or cost prohibitive, the Department shall review alternative proposals by a qualified professional which prioritize:
 - a. Locating the grease interceptor outside of food preparation, storage and service areas, and
 - b. Provide the greatest protection against potential spills or nuisance conditions.
6. Any alternative proposed to an outdoor 1,000 gallon minimum gravity grease interceptor shall include an operation and maintenance program and shall be subject to an operating permit.

M. Dispersal System Goals

1. Maximum trench or bed or drip line depth is dictated by depth of effective soil and groundwater separation.
 - a. The following effective soil depth shall be provided in the OWTS dispersal area for those systems which discharge to the ground including the replacement area:
 - i. Conventional OWTS shall provide for a minimum of four (4) feet of effective soil depth beneath trench or bed bottom
 - ii. Pressure dosed OWTS shall provide for a minimum of three (3) feet of effective soil depth beneath trench or bed bottom
 - ii. Mound dispersal systems shall provide for a minimum of two (2) feet of effective soil depth beneath original surface grade and at least three (3) of permeable material above an impervious horizon,
 - iii. OWTS including supplemental treatment shall provide for a minimum of two (2) feet of effective soil depth beneath trench or bed bottom.
 - b. The following vertical separation between point of discharge and any seasonally saturated horizon shall be provided for those systems which discharge to the ground including the replacement area
 - i. Conventional OWTS shall provide for a minimum of five (5) feet of vertical separation beneath trench or bed bottom
 - ii. Pressure dosed OWTS shall provide for a minimum of five (5) feet of vertical separation beneath trench or bed bottom
 - iii. Mound dispersal systems shall provide for a minimum of two (2) feet of vertical separation between original surface grade and any

- seasonally saturated horizon
- iv. OWTS incorporating supplemental treatment shall provide for a minimum of two (2) feet of vertical separation between trench or bed bottom and any seasonally saturated horizon.

N. Gravity Leaching Trenches

1. Gravity fed leaching trenches may be as narrow as eighteen inches and as wide as three feet. Any single trench wider than three feet shall be considered a leaching bed. No single gravity fed trench may be more than 100 feet in length.
2. The application area of any gravity fed aggregate filled leaching trench shall be all bottom area and any sidewall in excess of 12 inches below the distribution lateral up to a maximum of three feet of sidewall on each side of the trench.
3. The application area of any chambered leaching trench shall be nominal bottom area only. No reduction in square footage shall be allowed for chambered dispersal systems.
4. The minimum depth for any trench shall be measured on the down slope sidewall; the maximum depth shall be measured on the up slope sidewall.
5. The minimum depth for conventional, gravity fed trenches using drain rock shall be twenty-four inches to allow for at least six inches of drain rock below and two inches of drain rock above the four inch lateral and twelve inches of soil cover above the siltation barrier without capping fill.
6. The minimum depth for conventional, gravity fed trenches with leaching chambers, half pipe, or similar drain rock substitutes, shall allow for at least twelve inches of soil cover over all parts of the chamber or drain rock substitute without capping fill. Actual minimum depth shall be determined by the designer and will vary based on the product used, slope and trench width.
7. Leaching trenches shall be constructed level from end to end and from side to side. There should be no more than 3 inches of grade difference per 100 feet.
8. Leaching trenches shall, to the extent possible, be constructed on contour so that depth remains uniform from end to end.
9. When necessary on sloping ground to prevent excessive trench depth, leach lines shall be stepped. The lines between each horizontal section shall be made with watertight joints and shall be designed so each horizontal leaching trench shall be

- utilized to the maximum capacity before the effluent shall pass to the next lower leach line. The lines between each horizontal leaching section shall be made with approved watertight joints. When stepped trenches are constructed, a minimum of five feet of undisturbed soil shall remain in place between the trench ends.
10. Where possible, gravity distribution to two or more trenches or beds shall result in equal rather than serial distribution. Trench or bed lengths shall also be equal or proportional so that equal distribution may be achieved through the use of a distribution box or boxes.
 11. Distribution boxes shall be water tight and bedded in concrete to prevent shifting after installation.
 12. Fittings or speed levelers shall be used to fine tune the flow to two or more outlets from the distribution box.
 13. If equal distribution is not feasible, such as when trenches of proportional lengths cannot be constructed, or trenches must be installed off contour and “stepped” before the maximum allowable depth is reached, serial distribution may be approved by the Department. If the site is severely constrained and gravity distribution is unlikely to produce effective results, the applicant may be referred to a qualified professional for a pressure dosed design.
 14. Minimum spacing between trenches shall be four feet plus two feet for each additional foot of depth in excess of one foot below the bottom of the drain line.
 15. Before placing drain rock, chambers or approved alternative in a trench, all smeared or compacted surfaces shall be raked, and loose material removed. Walking in disposal trenches is strongly discouraged as foot traffic can have the effect of compacting infiltrative surfaces impeding permeability.
 16. When perforated pipe is used, it shall be laid level, extend the full length of the trench, and the end of the line shall be capped. Perforated distribution pipe for gravity-fed standard OWTS’s shall be of four (4) inch inside diameter of Acrylonitrile-Butadiene-Styrene (ABS), clay, concrete, polyethylene (PE), polyvinyl chloride (PVC) (1,000 pound minimum crush) with American Society for Testing and Materials (ASTM) approved and in accordance with California Plumbing Code (CPC) standard, or equivalent.
 17. Drain rock shall be clean, $\frac{3}{4}$ ” – 2 $\frac{1}{2}$ ” in size, and have a hardness value at least 3.0 on mohs scale. Not more than five (5) percent by weight shall pass a number ten (10) sieve. The drain rock shall be protected from soil infiltration during backfill by a layer of non-woven landscaping fabric, untreated building paper, or other material approved in advance by the Department.

18. Leaching chambers shall not be used unless reviewed and approved by the Department, shall be certified to meet IAPMO PS 63-2005, and shall be installed consistent with the manufacturer's instructions. Any other product intended for use in lieu of drain rock shall be submitted for review and approval by the Department.
19. Inspection pipes shall be located at the distal end of each trench or as required by the design in any bed or other structure. Pipes shall be 4 inch diameter, shall be perforated in the zone being monitored. Pipes shall extend to the bottom of the interval being monitored except in the case of chambers where the pipe may terminate at the top of the chamber. Inspection pipes shall extend at least 6 inches above grade or shall be finished flush with the surface and provided a suitably sized valve box for access. Pipes shall not be connect to the distribution lateral. Each inspection pipe shall be fitting with a non-cemented cap that may be removed by hand for inspection.
20. Trenches shall be provided with a minimum of 12 inches soil cover after settling. Soil cover shall be crowned to reduce the potential for excessive precipitation infiltrating the OWTS.

O. Pressure Dosed Leaching Trenches

1. Pressure-dosing OWTS is required when:
 - a. Percolation rates at trench bottom average slower than 60 but no slower than 120 minutes per inch. Where the average perc rate is slower than 120 mpi but at least 240 mpi, supplemental treatment shall also be included.
 - b. Percolation rates at trench bottom average faster than 5 minutes per inch and no perc test was faster than 1 mpi. Where any individual perc test is faster than 1 mpi, supplemental treatment shall be included.
 - c. Effective soil depth demands a dispersal system shallower than suitable for a conventional OWTS.
 - d. The OWTS requires 500 linear feet of trench or more.
 - e. The OWTS incorporates supplemental treatment.
 - f. The OWTS includes mound or at grade disposal.
2. Pressure-dosed systems shall be designed by a qualified professional.
3. Hydraulic calculations shall be included to demonstrate that pump, head losses, orifice diameter and spacing will produce a minimum residual head of five (5) feet at every orifice.

3. Pressure-dosed systems shall employ a piping system which distributes effluent evenly throughout the system in doses which allow the soil to rest between applications. Where the system is dosed by a pump, the minimum dose volume shall be at least 2X the volume of the pipe to be charged. Maximum dose volume shall not exceed 33% of the daily design flow. Where the system is dosed by a siphon, the design shall demonstrate the dose volume needed to achieve system pressurization. Systems should be designed such that trenches or beds drain completely free of effluent between doses.
4. When pressure pipe is used, it shall be specified by the qualified professional and designed for the particular application with a design pressure rating greater than one and one half (1-1/2) times the maximum working pressure. The minimum standard shall be equal to ASTM schedule 40 PVC. PVC pressure lateral risers (inspection risers) shall be protected by being placed in a sleeve pipe or yard box. Lateral risers shall be equipped with a forty-five (45) degree elbow or sweep.
5. Pressure dosed leaching trenches may be as narrow as twelve inches and as wide as three feet. Any single trench wider than three feet shall be considered a leaching bed. The maximum length of any single pressure dosed trench shall be limited by the ability to maintain residual head within 10% from the first orifice to the last.
6. Equal distribution per unit area shall be achieved by the use of pressurized laterals with equally sized and spaced drilled orifices and trimmer valves to adjust the pressure at each trench during a construction inspection or by differentially sized and/or spaced drilled orifices combined with the elevation differences to yield equal distribution per unit area.
7. The application area of any pressure dosed leaching trench shall be bottom area only. Exception shall be made in the case of a repair where severe area limitations preclude a design based on bottom area only.
8. The minimum depth for any trench shall be measured on the down slope sidewall; the maximum depth shall be measured on the up slope sidewall.
9. The minimum depth for pressure dosed leaching trenches utilizing drain rock shall be at least nine inches to allow for at least six inches of drain rock below the lateral and two inches of drain rock above the lateral. Capping fill shall be included as needed to provide a minimum of 12" soil cover over the siltation barrier. Trenches shallower than this shall be considered at grade dispersal.
10. The minimum depth for pressure dosed leaching trenches utilizing chambers, half pipe, or similar drain rock substitutes, shall be such that the down slope trench

sidewall shall be at least as high as chamber side louvers and the chamber or other rock substitute shall be at or below the original grade at all points. Capping fill shall be included as needed to provide a minimum of 12" soil cover over all parts of the chamber. Trenches shallower than this shall be considered at grade dispersal.

11. When soil depths are shallow, and the disposal field design provides at least 3 but less than 4 feet of soil below trench bottom, profile holes and percolation testing shall establish an area at least 50 feet down slope of the disposal field which has a minimum of 3 feet of permeable soil to accommodate effluent migration downhill. This area shall be under the control of the property owner and shall remain free of structures, cut banks, or other activities that would increase the risk of surface discharge of partially treated sewage.
9. Leaching trenches shall be constructed level from end to end and from side to side. There should be no more than 3 inches of grade difference per 100 feet.
10. Leaching trenches shall, to the extent possible, be constructed on contour so that depth remains uniform from end to end.
11. Where the design specifies orifices are to point up, orifice shields or chambers shall be used to prevent scouring through the soil cover. Where the design specifies orifice are to point down, a minimum of six inches of drain rock below the pipe shall be provided.
12. Minimum spacing between trenches shall be four feet plus two feet for each additional foot of depth in excess of one foot below the bottom of the distribution lateral.
13. Before placing drain rock, chambers or approved alternative in a trench, all smeared or compacted surfaces shall be raked, and loose material removed. Walking in disposal trenches is strongly discouraged as foot traffic can have the effect of compacting infiltrative surfaces impeding permeability.
14. Drain rock shall be clean, $\frac{3}{4}$ " – 2 $\frac{1}{2}$ " in size, and have a hardness value at least 3.0 on mohs scale. Not more than five (5) percent by weight shall pass a number ten (10) sieve. The drain rock shall be protected from soil infiltration during backfill by a layer of non-woven landscaping fabric, untreated building paper, or other material approved in advance by the Department.
15. Leaching chambers shall not be used unless reviewed and approved by the Department, shall be certified to meet IAPMO PS 63-2005, and shall be installed consistent with the manufacturer's instructions. Any other product intended for use in lieu of drain rock shall be submitted for review and approval by the Department.

16. Inspection pipes shall be located at the distal end of each trench or as required by the design in any bed or other structure. Pipes shall be 4 inch diameter and shall be perforated in the zone being monitored. Pipes shall extend to the bottom of the interval being monitored except in the case of chambers where the pipe may terminate at the top of the chamber. Inspection pipes shall extend at least 6 inches above grade or shall be finished flush with the surface and provided a suitably sized valve box for access. Pipes shall not be connected to the distribution lateral. Each inspection pipe shall be fitted with a non-cemented cap that may be removed by hand for inspection.
17. Trenches shall be provided with a minimum of 12 inches soil cover after settling. Soil cover shall be crowned to reduce the potential for excessive precipitation infiltrating the OWTS.
18. Distribution lateral ends shall be fitted with a 90° sweep and access riser to the surface fitted with a water tight threaded cap and protected by a 4 inch pipe sleeve and slip on cap or finished flush with a valve box to provide access for maintenance or inspection.

P. Leaching Beds

1. Trenches are generally preferred for OWTS design but where dispersal trenches are not feasible, a bed or beds may be approved provided that setbacks, slope and effective soil depth are conducive to such as design.
2. Leaching beds may be gravity fed or pressure dosed and shall comply with the applicable guidelines for laterals, materials, maximum length, etc.
3. Linear loading rate and hillside flow analysis (Darcy's equation) shall be considered when designing a bed.
4. Leaching beds shall be constructed with level bottoms and on contour so that depth remains uniform from end to end.
5. Leaching beds shall be sized based on bottom area only. Where possible, a gravity fed dispersal bed shall be sized to provide 50% more application area than a trench system. Pressure dosed beds may be designed with the same application rate as trenches. Distribution laterals in a leaching bed shall be separated by no more than 36 inches, center to center.
6. Materials used in the construction of leaching beds shall be consistent with those approved in trench systems.

7. Leaching beds shall be provided with at least 12 inches but no more than 24 inches of soil cover after settling. Soil cover shall be crowned to reduce the potential for excessive precipitation infiltrating the OWTS. Care must be taken to avoid excessive cover depth to encourage evapotranspiration and aerobic conditions within the bed.
8. A minimum of one (1) inspection pipe shall be provided for each 200 square feet, or portion thereof, of leaching bed area.

Q. At Grade Beds

1. At grade dispersal shall only be approved for use with OWTS incorporating supplemental treatment
2. At grade dispersal shall be limited to sites with no more than 20% slope unless supported by a slope stability assessment and includes design features to stabilize the fill.
3. The "site" is all that area intended to function as the disposal bed site, 100% replacement area, and all area within fifty feet downslope of either or both of these areas. The following criteria apply to the "site" as described above.
 - a. Minimum of 24" effective soil depth is required and a minimum 24" to highest anticipated ground water level. If there is any question about the presence of ground water, wet weather testing shall be required.
 - b. A minimum of three perc tests shall be performed at 18" and three at 24" demonstrating 60 mpi or faster at 18 inches and 90 mpi or faster at 24 inches.
 - c. Convex or simple contours are suitable for design. Designs on concave slopes are strongly discouraged and may require additional testing or design features.
4. Application rate shall not exceed 0.6 GPD/SF regardless of soil characteristics. The basal area for determining application rate is the length of the distribution lateral multiplied by bed width downslope from the lateral to the downslope toe of aggregate, the latter dimension not to exceed eight feet.
5. Designs shall maximize available length of contour (i.e. long, narrow beds are preferred). Designs shall be justified using the linear loading rate based on soil texture and structure such as described by E. J. Tyler's 2000 paper, "Hydraulic Wastewater Loading Rates to Soil", by the use of Darcy's equation, or by other analysis demonstrating that effluent will not resurface within the site, including all area within fifty feet downslope of the disposal bed.

Darcy's equation $Q = K \cdot i \cdot A$, where:
 Q = daily design flow expressed in cubic feet
 K = hydraulic conductivity of site soil
 i = the gradient of the limiting layer
 A = the cross-sectional area perpendicular to the flow direction
 (lateral length X effective soil depth)

Hydraulic conductivity, K , shall be based on published materials establishing infiltration rates based on soil type or derived from percolation test results using the Porchet method; equation and graph are shown below.

$K = \frac{\Delta H \cdot 60 \cdot r}{\Delta t (r + 2 \cdot H_{avg})}$, where
 ΔH = drop in inches in stabilized perc test
 Δt = time interval between readings
 r = radius of test hole
 H_{avg} = average water depth in test hole during Δt in inches

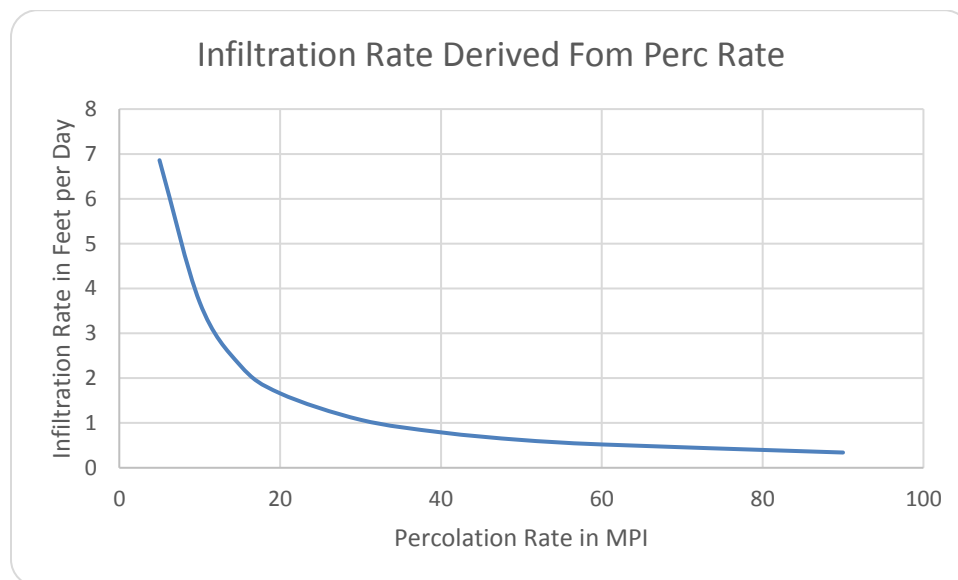

6. Disposal beds shall be constructed so as to provide a minimum of six vertical inches of aggregate below distribution lateral.
7. Distribution laterals shall be pressure dosed with cleanout risers accessible from surface. Cleanout risers shall be fitted with water tight, threaded caps which may be periodically removed for flushing. A sub-grade finish with valves and access risers to accommodate flushing is an acceptable alternative.

8. Lateral orifices shall be spaced as close together as is feasible.
9. Bed stacking must be justified by Darcy's equation, linear loading analysis or similar quantitative method acceptable to the Department.
10. A minimum of 12 inches of soil cover over a siltation barrier of non-woven geotextile fabric is required. The mounded cover shall extend a minimum of five feet upslope and sideslope from the bed and a minimum of fifteen feet downslope from the toe of the aggregate bed. The downslope toe must at no time exceed a 3:1 slope to meet the native grade. All disturbed areas must be seeded, fertilized, and mulched to encourage the growth of an erosion control cover crop.
11. A minimum of one groundwater monitoring pipe upslope and two downslope of each disposal bed is required. Where stacked beds are justified, no monitoring pipes shall be required between the beds. Monitoring wells shall be a minimum of 4 inches diameter with non-cemented caps.
12. A minimum of 2 inspection pipes are required per bed located at the downslope toe of the aggregate bed. Inspection pipes shall be so constructed so as not to be easily removed from the disposal bed, shall be 4 inches in diameter, and shall be fitted with non-cemented caps.
13. Beds shall be laid out so that the downslope toe of the aggregate bed is level. Due to slope variation from end to end, a uniform bed width may not result in the upslope toe of the bed being level. In such an event, the bed width shall be widened as needed to result in the lateral being placed level from end to end.

R. Mound Systems

1. Mound systems combine treatment with the dispersal field and may be used where conventional and modified conventional OWTS are not suitable. Mounds are alternative systems, subject to an operating permit but are not considered supplemental treatment by the Policy.
2. Mound system design shall comply with "Guidelines for Mound Systems" published by the State Water Resources Control Board in January 1980 as modified or amended by these regulations.
3. Perimeter groundwater monitoring pipes, a minimum of one upslope and two downslope, shall extend at least two (2) feet but not greater than four (4) feet into native soil, and shall be located 5 – 10 feet from the toe of soil cover. The Mound

- shall be provided at least one inspection pipe within the aggregate bed extending to the sand surface and at least one inspection pipe extend through sand fill to the native soil interface near the downslope toe of the sand. All inspection and monitoring pipes shall be 4 inches in diameter, and shall be fitted with non-cemented caps.
4. Percolation test standards in these regulations shall take precedence over the refined percolation test described in the State Water Resources Control Board document appendix. A minimum of six perc tests at 24" shall be required.
 5. The sand body fill shall have an effective size of 0.25 – 0.50 mm and a uniformity coefficient <4. Sand body fill application rate shall be 0.8 gallons per day per square foot. Table 3, Mound Body Fill Materials, page 16 of the State Water Resources Control Board document, is eliminated.
 6. Hydraulic calculations for the distribution laterals shall accompany all designs to demonstrate residual pressure is at least five (5) feet at every orifice.
 7. Analysis shall accompany each design demonstrating that effluent will remain subsurface for at least fifty (50) feet downslope of the mound aggregate bed.
 9. The basal application rate, determined by the length of the laterals multiplied by the downslope extent of sand fill, shall comply with the criteria for application rate based on soil texture or based on percolation rate established by these regulations. The maximum percolation rate allowed for a mound system is 90 mpi. Table 10, Native Soil Percolation and Design Infiltration Rates, page 37 of the State Water Resources Control Board document, is eliminated.
 10. Mound systems shall be limited to sites with no more than 12% slope. Steeper site shall not be graded to produce a slope of 12% or less.
 11. No mound design shall be designed or constructed on fill.
 12. The site must be field staked by the builder and approved by the designer and the Department before construction begins.
 13. Excessive vegetation is removed from the site and a 4 to 6 inch thickness of medium concrete sand is placed. The site is ripped on contour through the sand into the native soil to a depth of 12 inches. No wheeled equipment should then travel over any area so prepared before placement of protective materials such as drain rock, etc. to protect the prepared soil from compaction. All areas to be overlain by sand fill shall be so prepared. All areas to be overlain by the soil cover shall be ripped on contour to minimize any interface between native soil and the cover.

14. A minimum depth of 24" of sand body fill is placed below the distribution bed. The design shall specify the slope of the mound fill toes. The aggregate distribution bed is then constructed to the depth, width, and length called for by the design. The laterals are drilled and dry-assembled on the disposal bed(s), orifices pointing up. Joints are not cemented until after the pump test is complete.
15. The pump is run with all end caps removed to flush any debris from the laterals. Caps are then replaced and the pump test is witnessed by the designer and the Department.
16. Piping is rotated, if necessary, and cemented in place, any necessary orifice shields are installed. Drain rock is added if necessary per design specs. Geofabric applied over the distribution bed and soil cover is put in place. All inspection pipes, ground water monitoring wells, and erosion control measures are constructed. A final grading inspection may then be performed by the designer and the Department.

S. Drip Dispersal

1. Drip dispersal shall be limited to OWTS incorporating supplemental treatment.
2. Drip dispersal shall be provided a minimum of eight (8) inches of soil cover.
3. To be considered suitable for a Subsurface Drip Dispersal system, the site must have the following characteristics:
 - a. A well drained, stable, moderately concave or convex slope.
 - b. A slope of fifty-five (55) percent or less.
 - c. Able to comply with all setback requirements.
 - d. A percolation rate less than 240 mpi conducted at a depth of 18 and 24 inches below the ground surface.
 - e. Provides a minimum of 2 feet of permeable soil below bottom of dispersal field free of groundwater at all times.
4. Application area shall be assumed to be the gross area covered by drip line spaced per the manufacturers recommendations.
5. Where additional soil fill is required to provide conditions necessary for the design, the fill shall be placed pursuant to a design by a qualified professional prior to installation of the drip line.
6. Analysis shall accompany each design demonstrating that effluent will remain subsurface for at least fifty (50) feet downslope of the drip system.

7. The system must not be constructed when soil moisture is excessive. Both designer and the Department must agree that the site is ready before construction begins.
8. The Operation and Maintenance plan for the OWTS shall incorporate the manufacturers service requirements for the product.
9. A minimum of three perc tests shall be performed at 18" and three tests at 24" to support a drip design.

T. Pumps, Controls and Alarms

1. All electrical components used in OWTS shall comply with the California Electrical Code and the requirements of the Amador County Building Department.
2. Pumps shall be rated for wastewater application.
3. Motors shall be rated for continuous duty and shall be provided with overload protection.
4. Submersible pumps shall have a non-corrosive lifting device to allow ease of removal and service without requiring entry into the pump chamber.
5. Pumps shall be equipped with non-clog impellers capable of passing a 3/4 inch solid sphere or shall be protected by a cylinder of corrosion resistant screen extending above the maximum effluent level with one-eighth (1/8) inch maximum openings or other approved method.
6. Pumps and alarms shall be activated by sealed float switches, or other reliable devices approved by the Department. Control floats shall be set such that the volume discharged during each pump cycle is between fifteen (15) and fifty (50) percent of the design daily flow unless otherwise dictated by specific design criteria for the OWTS.
7. Alarms shall be provided for high water level and may be provided for low water level and various pump malfunction conditions such as pump seizure or overheating.
8. Alarms shall be both audible and visual. Audible alarms may be user cancellable. Visual alarms shall require a working knowledge of the control system to cancel such as would be possessed by a qualified service technician.

9. The alarm annunciator panel shall be located on or adjacent to the building which the pump system services. The panel shall also be visible and audible from the same structure. If the system control panel is outdoors, it shall be in an enclosure appropriately rated by the National Electric Manufacturer's Association.
10. Grinder pumps shall not be approved as part of an OWTS design or retrofit. Where raw sewage must be pumped, a pump designed to transport sewage with minimal maceration of solids shall be used.
11. Every pump tank or pump vault shall provide a minimum of one day design flow above the alarm on elevation for the structures or uses served by the pump.

U. Dosing Siphons

1. Dosing siphons may be employed where sufficient elevation difference and grade exists to produce the required minimum residual pressure in the distribution laterals.
2. Dosing siphons may be placed in the second compartment of a septic tank provided that the baffle separating the two chambers prevents changes to the liquid level in the primary chamber when the siphon discharges and the capacity of the primary chamber is at least equal to the minimum septic tank size required for the proposed use. Alternatively, siphons may be placed in a separate dosing chamber.
3. The design and construction of any separate siphon dosing chamber shall be consistent with the load bearing requirements, approved materials, buoyancy and water tight testing required for septic tanks
4. Inlet tees for siphon chambers shall terminate below the lowest normal operating liquid level.
5. Dosing siphons shall be equipped with rigid discharge piping.
6. Access to the siphon shall be provided via a minimum 24 inch diameter gas tight riser and lid that is locked or may only be removed by the use of tools.
8. Siphon dosing chambers shall be accorded the same sanitary setbacks as septic tanks.

V. Supplemental Treatment Units

1. Supplemental Treatment units are an appropriate OWTS component where:
 - a. Effective soil depth is not compatible with conventional or modified conventional systems but provides a minimum of 2 feet of permeable soil below bottom of dispersal field free of groundwater at all times.
 - b. Any one perc test reveals a rate at dispersal field depth faster than 1 mpi or the average of all tests at design depth is slower than 120 mpi but no slower than 240 mpi.
 - c. Where a variance is necessary to reduce the setback to a public water supply well or a surface water body with a public water system intake point within 2,500 feet of the OWTS and the OWTS could cause or contribute to impairment of the water body.
 - d. Where treatment is necessary to reduce BOD and TSS with regard to large or community OWTS.
2. Supplemental treatment units shall be designed to produce effluent which does not exceed a 30-day average BOD or TSS of 30 mg/L.
3. OWTS incorporating supplemental treatment are considered alternative systems and are subject to an operating permit, enrollment in CSA 6 and periodic monitoring by the Department.
4. Supplemental treatment systems shall be stamped or approved by a qualified professional. The designer of an OWTS incorporating proprietary treatment shall specify the minimum operation and maintenance program standard required for the treatment unit. The program shall meet or exceed the manufacturer's requirements to maintain coverage under any warranty. The designer shall state the third party or manufacturer's certification or other qualifications of the service provider for the OWTS. The permittee shall retain the services of a qualified service provider to service and maintain the identified system components consistent with the requirements established by the design. The permittee shall submit an annual report generated by the service provider including proof of the provider's third party or manufacturer's certification as required by the OWTS designer. The report shall summarize activities for the calendar year and shall be submitted to the Department no later than the following April 1.
5. Supplemental treatment units shall be afforded the same setbacks as a septic tank.
6. Intermittent sand filter design criteria include:
 - a. Application rate of effluent to ISF surface is 1.0 gallon per square foot per day.
 - b. Design shall provide for multiple dosing per day to the ISF. Minimum dose

- volume should not be less than two times the volume of the piping to be charged by the dose. Maximum dosing should not be greater than 25 percent of daily design flows.
- c. A minimum residual head of five (5) feet is required in the ISF distribution laterals.
 - d. Minimum orifice sizing shall be 1/8th inch in diameter and shall require 1/8th inch screening in the pump tank.
 - e. Filter media shall be a clean sand with an effective size (D10) of .25 to .50 millimeters in diameter. The uniformity coefficient should be 4 or less.
 - f. The depth of filter sand shall be 24 inches.
 - g. Drain rock below the filter sand is to be clean, small diameter, rounded rock. Rock associated with and below the distribution laterals is to be similarly clean. (Typically classified as double washed).
 - h. Intermittent sand filters shall be constructed on stable undisturbed earthen conditions or on fill placed, compacted and tested pursuant to an approved grading plan suitable to support structures.
 - i. Approved flexible membrane liners shall have properties which are at least equivalent to 30 mil unreinforced polyvinylchloride. Penetrations of the liner for piping, etc., shall be avoided to the extent possible. Where necessary, factory fabricated “boots” suitable for field bonding shall be used.
 - j. Liners shall be installed so as to preclude punctures and abrasions. Surfaces that are contacted by the liner shall be free of sharp edges, corners, roots, nails, wire, and other projections that might puncture, tear, or cut the liner. The bottom of the liner is to be protected by a layer of approximately 4 inches in depth of clean bedding sand raked smooth.
 - k. A capped monitoring pipe, minimum diameter of 4 inches, shall be installed at the interface of distribution rock and filter sand.
 - l. Durable filter fabric is required to be placed over the top of the distribution rock with fabric over lapping the sides approximately 6 inches. Final soil covering depth over the ISF unit is to be no less than 12 inches. Maximum soil covering shall not exceed 18 inches. Texture shall be loam or coarser. Finish grading to eliminate standing water and infiltration is required.
 - m. Minimum pump vault diameter shall be 21 inches.
 - n. A functional sampling tap assembly, designed to allow filling of a 12 inch high sample bottle, is required to be installed downstream of all intermittent sand filters. (½ inch minimum discharge)
7. No proprietary treatment unit shall be approved unless it is certified compliant with NSF/ANSI standard 40 or 245. Before any proprietary treatment unit may be included in a design it must be reviewed and approved by the Department.
 8. Dispersal fields following supplemental treatment shall be pressure dosed.

W. Capping Fill

1. Unless specific design criteria dictate otherwise, capping fill shall extend at least five feet up slope and side slope and ten feet downslope from any trench dispersal system. Capping fill shall extend at least five feet up slope and side slope and fifteen feet downslope from the edges of an at grade dispersal bed.
2. If capping fill is needed it may be imported or collected on-site from areas other than the dispersal field site and all areas within fifty feet of and down slope from the dispersal field. Capping fill shall be clay loam or coarser texture, approved by the OWTS designer and the Department, and shall not be excessively compacted.
3. Designs specifying capping fill placed on slopes steeper than 30% shall provide for jute netting stapled in place over seed and mulch or other methods as specified by the qualified professional in the slope stability assessment report. The purpose of these measures is stabilizing the fill until erosion control planting is established.

X. Interceptor Drains

1. Where interceptor drains are required, complete design plans shall be prepared by a qualified professional and submitted to the Department for review.
2. The bottom of the interceptor drain shall extend into a restrictive horizon.
3. The bottom and sides of the interceptor drain closest to the disposal field shall be lined with single ply polyvinyl chloride (PVC) or polyethylene (PE) plastic film which has a minimum thickness of twelve (12) mils.
4. The side of the interceptor drain trench farthest from the disposal area and the top of the drain rock must be lined with an acceptable filter fabric.
5. Four (4) to six (6) inches of clean drain rock or suitable equivalent as approved by the Department shall be placed in the bottom of the trench and perforated pipe sized for local site conditions shall be laid over this with the perforations placed down. Drain rock is placed over the pipe to a depth required by site conditions.
6. Minimum separation shall be maintained between interceptor drains and disposal trenches. In general, the following separations shall be maintained where site conditions allow:

- a. A minimum clearance of ten (10) feet must be maintained between an upslope interceptor drain and a disposal trench.
 - b. A minimum clearance of twenty-five (25) feet must be maintained between a laterally located interceptor drain and a disposal trench.
 - c. A fifty (50) foot minimum separation is required for a down-gradient interceptor drain to prevent infiltration of the drain with septic tank effluent.
 - d. Local site conditions may require a larger separation. The setbacks required in a, b and c above may be reduced based on a qualified professional's recommendation following a site specific evaluation and Department approval.
 - e. Down-gradient interceptor drains on slopes over ten (10) percent are generally not appropriate.
 - f. The qualified professional shall provide supporting documentation for the design.
8. The interceptor drain shall discharge by gravity to the surface and shall include energy dissipation considerations to prevent local erosion. The outlet shall be designed for ease of sampling the discharge, and shall be equipped with a perforated cap, stainless steel screening or other method to preclude entry of rodents or other small animals.
 9. The applicant is solely responsible to obtain any other permits or approvals which may be necessary due to construction of any interceptor drain systems.

Y. Engineered Fills

1. Where a parcel does not contain an adequate area with soil conditions compatible with any infiltrative design, a qualified professional may design an engineered fill and submit the plans to the Department for review and approval.
2. Engineered fills are better suited to sites with relatively permeable native soil. The fill should be designed to supplement existing effective soil depth to create a site that will comply with design criteria. Fill materials are typically loamy sand or sandy loam placed in six inch lifts, targeting roughly 85% relative compaction.
3. The applicant or designer submits at least three sets of plans prepared by a

- qualified professional for engineered fill to the Department along with the applicable review fee.
4. The Department reviews plans and advises applicant/designer of potential problems or concerns that may prevent issuance of disposal system permit. One set of approved plans is retained by the Department, one is provided to the applicant and one to the designer.
 5. Fill is placed per plan with any required inspections performed by the designer.
 6. Upon completion of fill placement and erosion control (on side slopes and other disturbed areas--not on top of the fill):
 - a. Compaction test results are provided to the Department.
 - b. Site Investigation (Soil Profiles) fee paid to the Department and soil profile pits inspected by the Department. Erosion control can be inspected at this time or when doing groundwater monitoring.
 - c. Unless waived, winter groundwater monitoring fee paid and Request for Winter Groundwater Monitoring filed with the Department.
 - d. Unless waived, groundwater monitoring pipes installed by property owner/designer during the dry season per engineered fill plans and observed, erosion control placed and inspected (if not previously done), by Department during the wet season.
 - e. Percolation testing performed by Designer and reported to the Department.
 - f. Sewage system disposal system designed by Designer based on criteria obtained during profiling, wet weather monitoring and percolation testing.
 7. Engineered fills shall not form the basis to approve the creation of new parcels.
 8. Every OWTS constructed on engineered fill shall be considered alternative and is subject to an operating permit.

VII. NON-DISCHARGE SYSTEMS

A. Evaporative Beds

1. Where soil conditions are not conducive to any form of infiltrative OWTS and evaporation potential is sufficient, a lined and covered evaporative bed may be designed and proposed by a qualified professional.
2. Evaporative beds serving residential use shall be designed based on an assumed flow of 112.5 gallons per bedroom per day.
3. The bed shall be of watertight construction and shall include a roof designed to preclude precipitation but maximize solar heating of the bed. The sides shall remain open to allow for removal by wind of moisture laden air above the sand.
4. The bed shall be filled with fine sand or similar media which has been tested to determine wicking potential. The depth and surface area of the bed shall be predicated on the wicking potential of the media.
5. The bed shall be designed to that effluent will remain below the sand surface at all times during the year.
6. The bed shall be provided with a minimum of four inspection pipes to monitor depth of effluent standing in the bed at any time.
7. The bed shall not be constructed on fill.
8. Evaporative beds are subject to an operating permit.

B. Holding Tanks

1. The Board of Supervisors declares that the policy of the county is not to allow the use of holding tanks anywhere in the unincorporated area of the county because sewage in holding tanks is not always stored, pumped, transported, and disposed of without said sewage polluting groundwater, surface water, or the environment generally. Only if exceptional circumstances exist which outweigh the dangers of the use of a holding tank for any specific parcel may a permit for a holding tank be issued.

2. The policy and the provisions of this section shall apply to all parcels in the unincorporated area of the county, regardless of the uses thereon, their general plan classification, and their zoning district.
3. Fees to cover the cost of administration of this section shall be adopted by ordinance of the board of supervisors and are required to be paid in order for any permit issued pursuant to this chapter to be valid.
4. No owner shall own, possess, use, install or maintain a holding tank or allow the ownership, possession, use, installation or maintenance of a holding tank without the prior obtaining from the health officer first of an installation permit therefor and the subsequent holding of a valid use permit therefor.
5. The Department shall not issue any installation permit or operating permit for a holding tank
 - a. Whenever the sewage to be held in the holding tank can be lawfully disposed of through use of a public sewer or of a conventional, alternate, special design, engineered, or nonresidential system; or
 - b. If new construction, increased intensity of use or creation of a subdivision would result from issuance of the permit for a holding tank.
6. Provided that none of the circumstances prohibiting issuance of a permit set forth above are or may be present if the permit is issued, the Department may issue an installation/operating permit for a holding tank only when it is determined:
 - a. That the use of a holding tank shall be temporary and is necessary to abate an existing or potential health hazard or nuisance while a failing system is being replaced or repaired or while a public sewer system is under construction and in any event not to exceed two years;
 - b. That the use of a holding tank is necessary because of a potential health hazard or nuisance from a failed or failing existing system no type of infiltrative system can be installed and used on that parcel;
 - c. That the applicant is a public entity or private person or entity providing public benefits such as public recreation and the use of a holding tank shall be on a seasonal or episodic basis only; or
 - d. That the holding tank is for a building designated as historical by the Board of Supervisors.
7. Holding tanks shall be structurally designed and constructed so as to be in conformance with the applicable standards for septic tanks set forth in the most recently adopted State Plumbing Code.

8. The system shall be of watertight construction with threaded pump-out cap, vent, and sewage inlet. There shall be a shutoff valve at the sewage inlet. An inlet water meter is required.
9. Holding tanks shall be of sufficient capacity to accommodate at least a seventy-two-hour continued filling after activation of an audio-visual alarm activated by a level sensing device.
10. Any facility served by a holding tank shall be fitted or retro-fitted with low-flow plumbing fixtures approved by the Department at the time of construction or reconstruction.
11. Holding tanks shall be pumped out at regular intervals and/or as required to prevent overflows and the contents removed to an approved septage disposal site by a liquid waste hauler registered with the Department.
12. Any owner desiring a permit for a holding tank shall file a joint application for a holding tank installation permit and a holding tank use permit with the Department. Said application shall be on forms provided by the Department and shall include the information required by Sections 14.12.040 and any other information required by the Department, including but not limited to, the plans and specifications for the holding tank and for its installation, designed by a qualified professional.
13. Whenever an applicant has filed an application pursuant to these regulations and has paid appropriate fees, the Department shall proceed as follows:
 - a. Make an inspection of the site to determine compliance with relevant provisions of Chapter 14.12 and these regulations.
 - b. If it is determined that the proposed holding tank complies with applicable codes and regulations, the Department shall give notice to the applicant by first class mail that the installation permit application is complete. Thereafter, the applicant shall have twenty working days to pay the installation permit fee. Upon payment of said installation permit fee, the health officer shall issue the installation permit; provided, that the Department has not learned of circumstances which justify denial of the installation permit. If the applicant fails to obtain the installation permit within twenty working days from the notice that the installation permit application is complete, the health officer shall not issue any installation permit based on that application.

- c. All applications for permits shall be processed, approved or rejected in writing by the Department within twenty working days. If the application is rejected, written notice thereof shall be sent to the applicant.
 - d. Any decision by the Department may be appealed to the Board of Supervisors pursuant to Amador County Code Chapter 2.92.

- 13. The Department may issue an installation or a use permit only upon certain conditions, including, but not limited to:
 - a. Specified periodic pumping;
 - b. Specified periodic inspection and maintenance;
 - c. Posting of a performance bond to insure that funds will be available for required pumping and maintenance thereof;
 - d. A limit on the number of persons using in any specific period the facility served by the holding tank;
 - e. The permit's being valid for a specified time period; and
 - f. Imposing reasonable limitations on the use of the facility being served by the holding tank.

- 14. Every installation and use permit shall contain the condition that as soon as a public sanitary sewer system becomes available, the owner shall connect to it within ninety days of formal notification by the sewerage agency of its availability. The use of the holding tank shall then be discontinued and the tank removed or converted as appropriate for use in the new connection.

- 15. As a further required condition, each owner shall agree to defend, indemnify, and hold harmless the county, its officers, employees, agents and servants from any liability for personal injury or property damage brought by or on behalf of the owner or any third party or for any costs which may be incurred as a result of any act or omission occurring pursuant to the provisions of this chapter, including the issuance of any permit.

- 16. An installation permit shall be valid for an initial period of thirty days from the date of its issuance. Within said initial period, the owner must complete installation of the system and obtain the health officer's final inspection and final approval of the system or the installation permit shall automatically lapse and be of no further force or effect. If an installation permit lapses before the Department gives final approval of the system, no person may work on or use the holding tank for which the installation permit was issued until the owner obtains a new installation permit. The installation permit shall be posted at a visible location on the property when work commences and shall remain posted until inspected and final approval is issued by the Department.

17. If an owner submits to the Department an application for an installation permit extension while said installation permit is still valid, the Department may grant one extension of the installation permit for a period of thirty days for the sole purpose of allowing the owner to complete installation and obtain final approval of the holding tank, unless the health officer has evidence of circumstances justifying denial of the renewal.
18. No work done under any installation permit shall be covered, concealed, or put into use before it has been inspected and approved in writing by the Department. The Department shall be given at least three working days' notice after completion of work to provide final inspection.
19. Once the installation of a holding tank pursuant to a valid installation permit has been given final approval by the Department, an operating permit shall be issued therefor. An operating permit shall be issued only upon approval by the Department of the stated use and design plans, satisfactory installation of the tank, recordation of the existence of the holding tank on the parcel, presentation of a satisfactory pumping contract, and proof satisfactory to the Department that the owner has complied with all required conditions. The operating permit shall be valid for one year subject to renewal on a yearly basis thereafter; provided, that the Department has not learned of circumstances which justify denial of the renewal. Transfer of ownership of the parcel for which the holding tank is permitted does not invalidate an otherwise valid use permit for that parcel. Only an owner holding a valid operating permit may use or permit to be used a holding tank.
20. The Department is authorized to make such inspections as are necessary to determine compliance with this chapter. Owners or occupants of real property shall give the health officer access to their property at reasonable times for the purpose of making such inspections as are necessary to determine compliance herewith. The Department may adopt and publish rules, regulations or policies concerning inspections, including notification requirements and frequency of inspections.
21. In the event of failure of the system or any portion thereof, or in the event pumping is not done in accordance with this chapter or any permit issued thereunder, the Department shall have the right to enter upon the property, cause the holding tank to be pumped and its contents transported to an appropriate place of discharge at the sole expense of the owner, including administrative and legal costs, and shut the holding tank down. The owner shall be entitled to a notice hearing before the Board on the issue of the expenses incurred by the

Department, and if said Board ascertains after said hearing that the county has incurred costs in pumping the holding tank and transporting the contents a lien shall be recorded against the property in the amount of said costs plus reasonable interest. This procedure may be used by said board or the Department may obtain a judgment against the owner for said costs.

C. Vault Toilets

1. Vault toilet facilities are appropriate for use in remote locations such as campgrounds, roadside comfort stations or outdoor recreational areas where there is no running water supply. The Department does not consider vault toilets an acceptable means of wastewater management for the purpose of approving a new or expanded use of structures supplied by running water.
2. Vault toilets shall provide sufficient space for comfortable use.
3. Toilets shall be designed, constructed and maintained so as to prevent the access of flies to the excreta.
4. The inside surfaces of all toilets shall be of durable, nonabsorbent material, smooth, easily cleanable, and finished in a light color.
5. The toilets shall be ventilated and provided with self-closing doors, lockable from the inside.
6. The vault shall be water tight construction, designed by a professional engineer to be capable of withstanding all anticipated forces, and of sufficient capacity to store wastes until serviced by a registered pumper. Size and construction shall be such as to prevent splashing on the occupant. A minimum vault capacity of 1,000 gallons shall be provided.
7. Toilets shall be maintained in a clean and sanitary manner.

D. Chemical Toilets

1. Chemical toilets are appropriate to serve temporary peak use events such as concerts or festivals, for providing facilities at a construction site or similar remote location, or to provide temporary sanitation service in the event of a failed OWTS or to abate similar nuisance conditions. The Department does not consider chemical toilets an acceptable means of wastewater management for the purpose of approving a new or expanded use.

2. Chemical toilet facilities shall provide sufficient space for comfortable use. A minimum area of eight square feet, with a minimum width of two and one-half feet, shall be provided for each toilet seat. A minimum area of ten square feet, with a minimum of two and one-half square feet shall be required when a urinal is included. Sufficient additional space shall be included if handwashing facilities are within the facility.
3. Toilets shall be designed, constructed and maintained so as to prevent the access of flies to the excreta.
4. The inside surfaces of all toilets shall be of durable, nonabsorbent material, smooth, easily cleanable, and finished in a light color.
5. The toilets shall be ventilated and provided with self-closing doors, lockable from the inside.
6. The tanks for chemical toilets shall be constructed of durable, easily cleanable material. Tank size shall be sufficient to contain the initial chemical charge and provide capacity for at least one day's use for forty persons. Size and construction shall be such as to prevent splashing on the occupant, field or road while being transported. A minimum tank capacity of forty gallons shall be installed in the toilet.
7. Chemicals capable of controlling odors and liquifying solids shall be used in chemical toilets.
8. Disposal of contents of chemical toilets shall be into a water pollution control plant or in an approved sanitary land fill.
9. All chemical toilets shall be serviced by a business registered with the Department and shall be maintained in a clean and sanitary manner, free of odors and stains.
10. Each chemical toilet must be identified with the name and telephone number of the company providing the service. The lettering shall be at least three inches in height on the exterior of the unit. Toilets must be stored at a site approved by the Department. The registered business is ultimately responsible for nuisance conditions related to use, maintenance and storage of the chemical toilets.
11. Permits for use of chemical toilets at construction sites, special events, etc., are not required by the Department.

E. Composting or Incinerating Toilets

1. The Department does not consider composting or incinerating toilets an acceptable means of wastewater management for the purpose of approving a new or expanded use. These units are not considered a suitable solution to address a failed OWTS.
2. Composting and incinerating toilets are not prohibited by the Department. Any nuisance conditions related to the use of these units shall be abated in a manner consistent with Chapter 14.12 and these regulations.
3. The Department will not issue a construction or operating permit for composting or incinerator toilets.
4. These toilets have the potential to expose the operator and others to health hazards. Extreme care should be exercised in managing the waste stream from these units. The Department advises that the residue not be used as a soil amendment or fertilizer or disposed where persons or animals may come into contact. Disposal at a sanitary landfill or transfer station is recommended.

VIII. OPERATION, MAINTENANCE, & MONITORING

A. Tier 0 OWTS

1. Existing OWTS constructed in compliance with laws in effect at the time, that are properly functioning and do not meet the conditions of failing systems or otherwise require corrective action (for example, to prevent groundwater impairment) as specifically described in Tier 4 of the Policy, and are not determined to be contributing to an impairment of surface water as specifically described in Tier 3, are automatically included in Tier 0.
2. Operation of Tier 0 systems shall continue as authorized prior to the adoption of these regulations unless and until the OWTS dispersal field undergoes major repair, expansion or replacement. At that time, the OWTS will be required to comply with the siting, design and operating criteria established by Amador County Code Chapter 14.12 and these regulations.

B. Tier 1 OWTS

1. With the implementation of these regulations every new, expanded or replacement OWTS shall be considered tier 2 and no OWTS shall be considered Tier 1.

C. Tier 2 OWTS

1. All new OWTS, including existing OWTS that have undergone major repair, expansion or replacement, and any OWTS for which oversight of operation has been transferred from the Central Valley Regional Water Quality Control Board to the Department shall be operated pursuant to Tier 2 requirements which include:
 - a. Do not grade, fill, place any concrete or other hard surfaces, construct buildings or enclose large livestock, such as horses and cattle, over or within 10 feet of the OWTS including the 100% replacement area. This does not preclude grading or placement of fill to create or improve site conditions for successful OWTS operation.
 - b. Do not direct surface water flow toward the OWTS.
 - c. Do not increase waste flows to the OWTS beyond the design capacity. Do not discharge hazardous waste to the OWTS. Do not regularly discharge the contents of a recreational vehicle holding tank to an OWTS. Do not discharge ion exchange regeneration wastewater to an OWTS. Minimize the amount of solids discharged to the OWTS.
 - d. Have the septic tank pumped out by a registered pumper as needed to

- prevent solids from migrating to the dispersal field or supplemental treatment unit. Pumping at least once every five years is generally appropriate, unless more frequent pumping is required by the OWTS designer or operating permit or is advised by a registered pumper.
- e. If the OWTS includes an effluent filter, have it cleaned or serviced at the same time the tank is pumped or more frequently if advised by the manufacturer.
 - f. Do not substantially change the character of use served by the OWTS without authorization by the Department.
 - g. If an operating permit has been issued for the OWTS, comply with all conditions of that permit.
2. Alternative OWTS are subject to an operating permit and enrollment in CSA 6. The permittee shall comply with all terms and conditions of the operating permit, including but not necessarily limited to:
- a. Assure that the OWTS is made available for monitoring by the Department.
 - b. Where the OWTS includes proprietary supplemental treatment or dispersal field equipment, retain the services of a qualified service provider to service and maintain the identified system components. The permittee shall submit an annual report generated by the service provider including proof of the provider's third party or manufacturer's certification as required by the OWTS designer. The report shall summarize activities for the calendar year and shall be submitted to the Department no later than the following April 1.
 - c. For those systems requiring electrical power to operate, maintain electrical power to the OWTS at all times, including during vacations and extended periods of absence. Occasional non-voluntary power outages caused by weather, fire, or routine maintenance and similar activities by the power supplier shall not be deemed a breach of this section.
 - d. Maintain the dispersal field and groundwater monitoring riser pipes in order to monitor liquid levels.
 - e. Pay, when due, any charges or assessments related to operation of the OWTS.
3. Large and community OWTS are subject to an operating permit and enrollment in CSA 6. The permittee shall comply with all terms and conditions of the operating permit, including but not necessarily limited to those listed for alternative OWTS and:
- a. The OM&M program plan shall be included as part of the OWTS design.
 - b. The operating permit shall establish discharge prohibitions, monitoring and reporting standards substantially conforming with waste discharge requirements and monitoring programs issued by the Central Valley Regional Water Quality Control Board for comparable discharges.
 - c. Operators of community OWTS must have authorization to enter

- properties served to inspect septic tanks for accumulation of solids.
- d. Unless greater monitoring frequency is warranted, an annual monitoring report shall be generated for each calendar year and submitted to the Department no later than April 1, the following year. The report shall summarize the monitoring data, provide copies of laboratory results, and describe any repairs, corrections, or unusual events.
 - e. The Department shall, at a minimum, perform an annual inspection of large and community OWTS. The routine annual inspection shall be coordinated with the Control Board for comparable discharges. The monitoring and reporting program shall include sampling of groundwater and surface water within 500 feet down gradient of the dispersal field.

D. Tier 3 OWTS

At present there are no water bodies identified as impaired by pathogens or nutrients within Amador County, therefore no tier 3 systems exist or are anticipated.

E. Tier 4 OWTS

1. OWTS that require corrective action or fail, as defined by these regulations, are automatically included in tier 4 and shall be corrected as soon as is reasonably possible in a manner consistent with Chapter 14.12 and these regulations.
2. Corrective action involving major repair or replacement of a tank shall require the tank comply with the requirements of these regulations. Corrective action involving major repair, expansion or replacement of a dispersal field shall require the entire OWTS comply with Chapter 14.12 and these regulations.
3. Corrective action that does not involve OWTS repair or which is limited to a minor repair, as defined, shall not result in a requirement to upgrade or alter the OWTS to comply with Chapter 14.12 or these regulations.
4. Interim measures to mitigate impacts related to a failed system may be implemented with Department approval and an identified permanent solution. If the permanent solution is not feasible to implement within 12 months, the Department may require the owner enroll the property in CSA 6 and be subject to monitoring.
5. Failure to comply with corrective action directives by the Department or the Regional Board constitute a failure to meet the conditions of the waiver of waste discharge requirements contained in the Policy, and is subject to enforcement action.

F. OWTS Pumping and Inspection

1. Any person who offers to the general public the services of cleaning of septic tanks, chemical toilets, holding tanks, vault toilets, or any similar structures designed to contain or transport sanitary sewage shall hold an unrevoked registration issued by the Department pursuant to California Health and Safety Code Section 117400, et seq.
2. Registration shall only be issued where the applicant has identified one or more disposal sites that are approved to receive the waste. No registration shall be approved if an unapproved disposal site is proposed
3. All vehicles used to pump and/or transport wastewater shall be inspected by the Department. The name and telephone number of the registered business operating the vehicles shall be clearly displayed on each vehicle. Each vehicle shall be equipped with a spill kit including absorbent, disinfectant and containers to safely transport solid waste from a minor spill. The vehicle shall be at least half full at the time of inspection to verify that it does not leak.
4. All persons, including any employees, engaging in waste pumping or hauling shall have sufficient training to recognize and minimize health hazards including appropriate response to spills. At the time of the vehicle inspection the Department shall evaluate the operator to determine if they are sufficiently familiar with the equipment to be used, knowledge of sanitary principles and the laws and ordinances affecting human health or nuisances.
5. A registered pumper shall report to the Department and to the California State Warning Center, (800) 852-7550, any unauthorized sewage release of 1,000 gallons or more within 24 hours of discovery. A registered pumper shall report at their earliest opportunity, in no event more than 24 hours after discovery, any unauthorized release of sewage which discharges to or without corrective action likely will discharge to a stream, river, lake or other water body.
6. No later than 30 days after the end of the month, registered pumpers shall submit to the Department a report for each calendar month which includes
 - a. The name and address of the owner or tenant of each and every one of the premises where a septic tank, cesspool, or sewage seepage pit has been cleaned out by the registrant or his or her employees on his or her behalf and the date of each cleaning.
 - b. The location where the cleanings are disposed of and by whom.
 - c. Total volume pumped for the month

7. Septage may only be disposed at approved disposal sites. Currently, a private sector processing facility accepts the majority of septage generated within the County. Current throughput at this facility averages 385,000 gallons per month with a peak measured monthly volume to date of 546,000 gallons. Maximum plant treatment capacity is 70,000 gallons per day (2,100,000 gallons per month) and containment volume of all treatment and storage vessels is 100,000 gallons. Solids are separated via a belt press and direct hauled to a permitted sanitary landfill. Clarified effluent is metered into a sanitary sewer subject to acceptance criteria established by the sewerage agency. The sewerage agency will accept up to 35,000 gallons of treated effluent per day. At present there are no significant limitations on the waste streams or anticipated timeframes within which other provisions will need to be made. Other wastewater treatment facilities in nearby Counties have also accepted septage in the past, prior to the construction of the existing facility.
8. OWTS inspection for the purpose of advising lending institutions or loan underwriters shall be subject to the requirements established by the lender or underwriter. In the absence of such requirements, potential buyers are advised to learn what they can about the existing OWTS serving the property as a condition of an offer to purchase. It is recommended that the OWTS be inspected by a registered pumper who holds a valid class A or C-42 license issued by the State Contractor's License Board and a current Inspector certification by the National Association of Wastewater Transporters (NAWT) or the California Onsite Wastewater Association (COWA).
9. The Department recommends that in all cases inspection begin with review of our records to determine whether construction or operating permits exist and if any other information may be available about the OWTS.
10. It is recommended that OWTS inspection be performed by a qualified professional or a registered septic tank pumper and include:
 - a. Evaluation of size and condition of building sewer
 - b. Evaluation of all tankage to determine
 - i. Condition
 - ii. Capacity
 - iii. Number of chambers
 - iv. Whether water tight
 - v. Presence of sanitary tees or effluent filters
 - c. Evaluation of the condition of any pump or siphon
 - d. Evaluation of any control or alarm panel to verify operational
 - e. Evaluation of any supplemental treatment unit for condition, functionality, signs of stress or neglect, and apparent quality of effluent
 - f. Evaluation of dispersal field to determine

- i. Type of dispersal field
 - ii. Apparent signs of stress or failure
 - iii. Dimensions and location with regard to wells, water bodies, grading or structures
 - iv. Water test using 300 gallons of water to determine if dispersal system will accept flow without signs of stress or backing up
 - v. Where possible, a camera should be introduced into the dispersal field laterals to provide additional information
11. The inspection report should include a sketch that locates and dimensions the OWTS. The report should state the condition of OWTS components and indicate which should be serviced, repaired, expanded or replaced.
12. Any report which determines the OWTS has failed should include the specific reason(s) for the conclusion and any known or suspected causes or contributing factors to failure. The report should specify which components need to be repaired, expanded or replaced to correct the failure.
13. Any report which determines that the OWTS has not failed but which recommends repair, expansion or replacement should specify which components need to be repaired, expanded or replaced to enable recommending the OWTS to the buyer or lender.

G. County Service Area #6

1. County Service Area #6 (CSA 6) provides for the monitoring of OWTS by the Department. The Department performs annual monitoring of each septic system within the CSA.
2. Systems subject to monitoring by the CSA currently include those that are designed with supplemental treatment and relaxation of soil and groundwater separation standards, and systems that do not discharge to the ground.
3. CSA 6 was formed on March 29, 1991 as a dependent special district of the County. It was formed for the purpose of collecting sewage system monitoring fees for annual inspections by the Department.
4. The CSA is staffed and managed by the Department. Assessments paid to the CSA are collected and distributed to the Department by the Auditor-Controller.

IX. OWTS REPAIR, EXPANSION, REPLACEMENT

A. Failed OWTS

1. The Department shall notify the owner of a public well or water intake and the California Department of Public Health as soon as practicable, but not later than 72 hours, upon discovery of a failing OWTS as described in Policy sections 11.1 and 11.2 within the setbacks described in Policy sections 7.5.6 through 7.5.10. Notification shall be via telephone or email, if available, in addition to regular mail.
2. A system is failing if one or more of the following conditions exist, whether on an intermittent or ongoing basis:
 - a. Any portion of the OWTS discharges sewage or effluent to the surface of the ground. Observation of discolored and/or foul smelling water surfacing over a dispersal field or tank or discharging from any portion of the drainage plumbing shall be prima facie evidence of failure.
 - b. Contamination of surface water or groundwater that discharges to the surface of the ground. Testing may be required to help determine whether suspect surface water is contaminated by one or more OWTS. Results of analysis for constituents including but not necessarily limited to MBAS, electrical conductivity, nitrates, and bacteriology may be required in order to document whether there is a significant difference between suspect water and unaffected background water quality.
 - c. Contamination of ground water used as a source of drinking water or that is used for any other beneficial use.
 - d. The OWTS does not accept the intended waste flows at the rate they are normally generated without backing up or discharging from another fixture.
 - e. The OWTS does not treat wastewater in compliance with the design prior to discharge.
 - f. Any system that creates or contributes to nuisance conditions.
 - g. Any treatment unit which does not produce effluent meeting minimum standards established by these regulations.

B. Minor Repairs

1. If the OWTS had been Tier 0 prior to failure and correction can be accomplished without the need to expand or replace the dispersal field The OWTS shall not be

- required to comply with all Tier 2 criteria.
2. Minor OWTS repairs or corrections which do not require a construction permit include the following:
 - a. Elimination of excess flows due to plumbing leaks or additional uses not accommodated by the OWTS design.
 - b. Repair or replacement of the building sewer or effluent sewer.
 - c. Root removal from any portion of the OWTS. This does not include excavation and reconstruction of any portion of root bound leaching trenches or beds. The Department may, where repetitive failure caused by roots is documented, require more permanent corrective action to abate a continual health hazard.
 - d. Redirecting precipitation run on by rerouting roof drainage or recontouring the ground surface
 - e. Installation, repair or replacement of access risers or lids for any part of the OWTS. All access risers and lids shall maintain a gas tight seal to prevent nuisance conditions and prevent intrusion of groundwater, soil, or roots into the system. All lids shall be locking or require the use of tools to remove to minimize potential access by children or animals.
 - f. Repair, replacement or adjustment of a distribution box or distribution valve with an identical item or suitable substitute.
 - g. Repair or replacement or adjustment of a control panel, float switch, cycle counter, pump or dosing siphon with an identical item or suitable substitute.
 - h. Servicing or replacement of media in a proprietary supplemental treatment unit where that media is supplied by the manufacturer or the manufacturer's designee.

 3. The following minor repairs require a construction permit and inspection by the Department but do not trigger the requirement to bring the entire OWTS into compliance with these regulations:
 - a. Structural repair or replacement of the septic tank or dosing tank.
 - b. Replacement of a proprietary supplemental treatment unit pursuant to design and direction by a qualified professional.
 - c. Replacement or reconstruction of site-built supplemental treatment unit pursuant to design and direction by a qualified professional.
 - d. Reconstruction of the aggregate bed, including six inches or less of the upper sand fill surface pursuant to design and direction by a qualified professional.
 - e. Rerouting the effluent sewer to feed a different portion of the existing dispersal field to avoid a minor root-bound portion of the existing OWTS.

C. Major Repairs, Correction, Replacement

1. Construction to repair, correct, or replace the dispersal field for any reason shall be subject the OWTS to being made compliant with all applicable Tier 2 requirements of Chapter 14.12 and these regulations in effect at the time of construction.
2. Where compliance with these regulations is not possible or feasible but the OWTS will comply with Chapter 14.12, the applicant shall contact the Director to seek a variance. The repair or replacement OWTS shall comply with the criteria to the extent feasible.

D. Reconstruction

1. In order to support reconstruction of a structure that has burned or was demolished for any reason to be served by the existing OWTS, sufficient information is needed to determine that the system is of sufficient capacity, was legally constructed, and does not pose a health and safety threat.
 - a. Absent information to the contrary, sufficient capacity for existing residential OWTS shall be determined as:

# Bedrooms	Min Tank Size	Min Total Trench Length
1	750 gal	65 feet
2	750 gal	90 feet
3	1000 gal	135 feet
4	1200 gal	180 feet
5	1500 gal	225 feet
6	1500 gal	270 feet

- b. There should be some evidence that a permit was obtained for any OWTS constructed after 1989. Permits were required for OWTS constructed between 1964 and 1989 but are sometimes difficult to locate; system repairs or replacements during this time were often performed without a permit. Records for OWTS constructed prior to 1964 are virtually nonexistent.
- c. OWTS should be located entirely within the property served unless there exists an easement or similar provision for off-site location. OWTS should not be located within a conflicting easement or right of way.
- d. OWTS should substantially comply with setbacks and construction standards in effect at the time installed.
- e. No portion of the OWTS shall discharge or threaten to discharge to a water body or contaminate groundwater.
- f. No portion of the OWTS shall expose raw or treated sewage to the open

air nor shall it be easily accessible to wildlife, domestic animals or children.
g. The OWTS shall not cause or contribute to nuisance conditions.

2. Prior to authorizing reconstruction the Department shall review records to determine if a construction permit or similar documents exist describing OWTS components, dimensions and location. Record search shall also reveal whether there has been a history of reported failure, nuisance conditions or other problems related to the OWTS.
3. If records exist indicating the existing OWTS may reasonably be expected to serve the proposed reconstruction project and there are not unresolved complaints outstanding, a site visit shall be made by the Department to determine that there are no obvious indicators that the OWTS has been damaged or altered.
4. If the site visit does not reveal potential problems, the construction project shall be authorized. An inspection report by a registered pumper, a qualified professional or the Department dated within the prior 12 months is a suitable substitute for a site visit.
5. If existing records or site visit indicate the OWTS may be undersized, improperly located, installed or modified without the appropriate permit(s), or if there is evidence of potential damage or alteration, the Department shall require additional investigation, corrective action or replacement as appropriate to serve the proposed reconstruction.
6. If no records exist, the applicant shall be directed to pursue a descriptive permit to document the existing OWTS or to file an application to construct a new OWTS.

E. Expansion of use

1. Where expanded or additional use is proposed on a property beyond that authorized by the existing OWTS permit the OWTS shall be expanded or replaced to support the increased use and all components and operation shall comply with Chapter 14.12 and these regulations.
2. Where the expanded use is contained within a separate structure on the same property a separate OWTS may be constructed to support that use and no alteration of the existing OWTS serving the original use shall be required.
3. Where the expanded use will serve 20 or more persons or the increased combined wastewater flow on the property to 1,500 gallons per day or more, the operation of all OWTS shall be subject to an operating permit and enrollment in CSA 6.

4. Where the expanded or additional use will result in the OWTS serving structures on more than one legal parcel, the OWTS shall be subject to an operating permit and enrollment in CSA 6.

F. Change of Character of Use

1. Where a change in the character of use is proposed, the Department shall review the proposal. If the Department determines that the new proposed use will not result in increased flow to the OWTS and the waste strength will not increase, the proposed change in use shall be approved.
2. Where the Department determines that the proposed change in character of use could increase waste flows or result in higher strength waste, the applicant shall be directed to retain the services of a qualified professional to review the existing OWTS and the proposed use(s) and submit a report to the Department certifying that the existing OWTS may be expected to provide acceptable service for the proposed use or to specify any modifications, expansion replacement or treatment that would be needed for such certification to be possible.

G. OWTS Certification

1. Certification of the adequacy of an existing OWTS by a qualified professional shall include the following information
 - a. Description of the size, materials, dimensions and condition of the existing OWTS.
 - b. Estimated daily design flow capacity of the OWTS based on dispersal field dimensions, soil type, perc rate (if known), size of tank(s) or any treatment unit(s). Assumption that any existing residential system is capable of accepting daily flows of 150 gallons per bedroom is insufficient without additional supporting information.
 - c. Estimated daily wastewater flows to be generated by the proposed use. If the estimate is based on average measured historic flows for the particular operation or measured average flows of similar operations a safety factor equal to at least 50% shall be included. If based on information in the current California Plumbing Code, no additional safety factor need be included.
 - d. Any additional treatment, modification, repair or replacement required to gain certification.
 - e. Operational requirements to assure ongoing success of the OWTS.
 - f. The certification report shall include data gathered, calculations, any assumptions made and the results of any tests that support the conclusions.

X. LAND DEVELOPMENT

A. General Requirements for Land Divisions Proposing Individual OWTS

1. The Department shall not recommend for approval any parcel proposed to be created by land division which requires site modification to create a site compliant with conditions required for OWTS approved for land division unless the site modification has been constructed and demonstrated to be effective prior to recordation of a final map creating that parcel.
2. The Department shall not recommend for approval any parcel proposed to be created by land division which requires an off-site easement for OWTS or a water supply well.
3. No remainder or NAPOTS parcel shall result from a land division which does not comply with the requirements of Amador County Code Chapter 14.12 and these regulations regarding land divisions.
4. These criteria establishing OWTS designated disposal sites are based on reasonable expectations of residential use. It may be appropriate for other criteria to apply to land divisions proposing parcels intended for commercial, industrial or institutional use. Proponents of such projects should consult the Department in advance of filing a tentative map to determine whether other criteria may apply to their project.
5. The Department shall refer to the regional board any tentative subdivision map, or other development project, proposing the discharge of 10,000 gallons per day or more to a single OWTS.
6. The Department shall not recommend for approval any land division, change to the Amador County General Plan, or other discretionary land use project enabling an increased intensity of OWTS use beyond the density equivalent of a single family dwelling and the entitled second dwelling unit per five (5) acres unless an evaluation by a qualified professional demonstrates that wastewater loading shall not conflict with the Central Valley Salt and Nutrient Management Plan.
7. The Department shall not recommend for approval any parcel proposed to be created by land division which requires a variance to sanitary setbacks to sources of public water supply.

B. Preliminary review

1. The Department shall, upon request by a subdivider, provide informal preliminary review of a proposed subdivision for suitability for OWTS and shall render an opinion prior to submission of a tentative map. It is recommended that every land division project be informally reviewed by the Department prior to submission of the tentative map.
2. In cases where available information indicates a high probability that compliant sites for OWTS will be demonstrated for each and every proposed parcel, the Department is unlikely to recommend additional field work prior to recommending tentative approval of the project.
3. In cases where information is lacking or suggests location of compliant sites for OWTS may be difficult or impossible to locate for each and every proposed parcel, the Department will recommend field work prior to submittal of the project application, the nature and extent of which will be determined by the perceived degree of risk based on soil conditions typical of the area, proposed project density and other related factors affecting the probability of demonstrating an approved OWTS site for each and every parcel. In some cases project configurations must be significantly revised to accommodate OWTS sites which can affect other aspects of the project. This can cause delays or added costs to the subdivider.
4. In some instances, a subdivider may decide to postpone some or all review by the Department until after the project application is accepted. If it is not possible to accomplish sufficient fieldwork to satisfy the Department that a compliant OWTS site may reasonably be expected on each and every proposed parcel within the statutory time frame to process a project recommendation, the applicant may sign an agreement to waive the time frame in order to complete this work. Without sufficient information to support an opinion that a compliant OWTS site may reasonably be expected to be demonstrated on each and every parcel, the Department cannot recommend approval of the project.

C. Formal Review

1. Unless all required work to demonstrate proof of compliant OWTS sites for each and every parcel has been performed prior to tentative map approval, the

necessary items will be proposed as conditions to be met prior to recordation of the final map or maps.

2. For every undeveloped parcel to be created relying on OWTS, the following must be completed prior to recordation of the final map creating the parcels to demonstrate conditions compatible with OWTS design types approved for the size parcel proposed and the proposed water supply.

- a. Soil profile testing within each designated disposal site for each parcel. A minimum of three (3) soil profile tests shall be required and each test shall demonstrate soil conditions compliant with the design type proposed. The Department may require additional profile testing if soil conditions are marginal or highly variable.
- b. Percolation testing within each designated disposal site for each parcel. A minimum of six (6) percolation tests shall be required and each test shall demonstrate soil conditions compliant with the design type proposed. The Department may require additional testing if soil conditions are marginal or highly variable.
- c. Unless waived by the Department, wet weather testing within each designated disposal site for each parcel. A minimum of three (3) wet weather tests shall be required and each test shall demonstrate soil conditions compliant with the design type proposed. The Department may require additional profile testing if soil conditions are marginal or highly variable.
- d. Where native ground slope within any portion of a designated disposal site exceeds 30%, or if the Department observes signs indicative of unstable landforms, a slope stability assessment shall be prepared by an appropriately licensed professional and submitted to the Department for review.
- e. Each designated disposal site shall provide at least the following area:

Percolation Rate (minutes/inch)	Minimum Usable Disposal Area (sq. ft.)
41--60	12,000
21--40	10,000
11--20	8,000
Less than 10	6,000

- f. Any designated disposal site which does not provide the minimum square footage identified above shall be approved if a conceptual disposal system design prepared by a qualified professional is submitted, reviewed and approved by the Department which demonstrates that the area available is capable of serving at least a three (3) bedroom residential equivalent including 100% replacement area.

- g. The subdivider shall submit a report prepared by a qualified professional to the Department for review and approval which includes a plot plan for each proposed parcel locating and dimensioning the designated disposal site, soil profile logs, perc test results, wet weather testing results, and slope stability assessment. The designated disposal site polygons shall include dimensions and at least one tie to a property corner pin including distance and bearing. The locations of pertinent field testing, any existing or proposed wells within 200 feet of the disposal site, and any water bodies within 200 feet of the disposal site shall be shown. If the disposal site does not comply with the criteria for conventional sewage disposal pursuant to Amador County Code Chapter 14.12 and these regulations, the qualified professional shall demonstrate compliance with siting and design criteria for modified conventional, mound, at-grade or supplemental treatment by including a conceptual disposal system design which includes, at a minimum, a typical trench or bed cross section, a foot print or layout of the disposal system, topography in the disposal site, and required linear footage per bedroom. In all cases the conceptual design shall demonstrate that the area available is capable of serving at least a three (3) bedroom residential equivalent including 100% replacement area.

D. Parcel Size and Provision for Water Supply and Wastewater Treatment

1. The Department shall recommend for approval a proposed parcel five (5) acres or more in size to be served by an OWTS provided the designated disposal site fully complies with siting and design criteria for conventional, modified conventional, mound or supplemental treatment with pressure dosed trench OWTS. Water supply may be via individual wells or by an approved public water system. The Department shall also recommend for approval parcels this size which will be served by a sanitary sewer and either individual wells or an approved public water system.

2. The Department shall recommend for approval a proposed parcel at least one (1) but less than five (5) acres in size to be served by an OWTS provided the designated

disposal site fully complies with siting and design criteria for conventional or modified conventional OWTS and water supply is provided by an approved public water system. The Department shall also recommend for approval parcels this size which will be served by a sanitary sewer and either individual wells or an approved public water system.

3. Subdivisions proposing density averaging may not result in any parcels less than two (2) acres in size to be served by private wells and OWTS. Those parcels less than five (5) acres and at least two (2) acres in size shall be recommended for approval provided the designated disposal site fully complies with siting and design criteria for conventional or modified conventional OWTS.
4. No subdivision shall be recommended for approval if such land division or subdivision would create any parcel of less than forty thousand square feet in net size, as determined pursuant to Amador County Code Section 17.28.062, unless each such parcel is served by a sanitary sewer and an approved public water system.
5. The Department shall refer to the regional board any tentative subdivision map, or other development project, proposing the discharge of 10,000 gallons per day or more to a single OWTS.

E. Land Development Projects Proposing Community OWTS

1. For the Department to recommend a discretionary land development project proposing wastewater service to be provided by a new or existing community OWTS, the developer shall provide the Department a written statement from an approved public entity such as a city, the County or a special district, indicating that the entity is willing to accept ownership and operation of the community OWTS, subject to terms and conditions identified in the tentative acceptance document.
2. In addition to the field work identified for individual OWTS, the developer shall retain the services of a qualified professional to demonstrate that wastewater loading shall not conflict with the Central Valley Salt and Nutrient Management Plan. The report required prior to final map recordation shall include an evaluation for groundwater mounding, modeling to determine the lateral extent to which elevated nutrients may be expected to be detectable in groundwater, propose and justify a minimum setback to property boundaries from the community OWTS and replacement area.
3. A minimum buffer of 50 feet in all directions shall be provided between the community OWTS dispersal field, including all replacement area, and the boundaries of the parcel to be dedicated to the operating entity.

F. Boundary line adjustments

1. A boundary line adjustment shall not be recommended for approval if the new parcel configuration results in the necessity for a variance, an easement or an alternative OWTS where a compliant conventional or modified conventional OWTS was possible prior to the boundary line adjustment.
2. Where there is insufficient information regarding soil conditions and resultant parcels less than twenty (20) acres in size are proposed, the Department shall direct the proponent to perform soil profile testing under inspection by the Department to determine that the project complies with the requirement.
3. A boundary line adjustment is not a land division; the same criteria do not apply and the level of proof is much lower. Where field work is required, the Department shall only require that which is necessary to determine whether the project will likely comply result in an increased number of variances, easements or alternative OWTS as compared to the parcel configuration before the adjustment.
4. Parcels twenty (20) acres or more in size resulting from a boundary line adjustment shall not be required to demonstrate OWTS capacity to the Department.

XI. Graywater Systems

1. No permit or inspection shall be required for residential graywater systems discharging laundry water only provided that the discharge is limited to a single domestic clothes washing machine at a one or two family dwelling. The owner must comply with state regulations regarding design and use which are outlined below.
 - a. The design shall allow the user to direct the flow to the irrigation or disposal field or the building sewer. The direction control of the graywater shall be clearly labeled and readily accessible to the user.
 - b. The installation, change, alteration, or repair of the system does not include a potable water connection or a pump and does not affect other building, plumbing, electrical, or mechanical components including structural features, egress, fire-life safety, sanitation, potable water supply piping, or accessibility. Note: The pump in a clothes washer shall not be considered part of the graywater system.
 - c. The graywater shall be contained on the site where it is generated.
 - d. Graywater shall be directed to and contained within an irrigation or disposal field.
 - e. Ponding or runoff is prohibited and shall be considered a nuisance.
 - f. Graywater may be released above the ground surface provided at least two (2) inches (51 mm) of mulch, rock, or soil, or a solid shield covers the release point. Other methods which provide equivalent separation are also acceptable.
 - g. Graywater systems shall be designed to minimize contact with humans and domestic pets.
 - h. Water used to wash diapers or similarly soiled or infectious garments shall not be used and shall be diverted to the building sewer.
 - i. Graywater shall not contain hazardous chemicals derived from activities such as cleaning car parts, washing greasy or oily rags, or disposing of waste solutions from home photo labs or similar hobbyist or home occupational activities.
 - j. Exemption from construction permit requirements of this code shall not be deemed to grant authorization for any graywater system to be installed in a manner that violates other provisions of this code or any other laws or ordinances of the Enforcing Agency.
 - k. An operation and maintenance manual shall be provided. Directions shall indicate the manual is to remain with the building throughout the life of the system and indicate that upon change of ownership or occupancy, the new owner or tenant shall be notified the structure contains a graywater system.
2. Any graywater system other than that described above shall require a permit

issued by the Department.

3. Graywater systems shall be designed based projected daily flow.
 - a. For a residence the daily flow of a laundry only system is determined to be at least (Number of bedrooms +1) X 15 gallons = Daily flow in gallons per day (GPD)
 - b. Graywater systems for all residential graywater shall determine the daily flow to be at least (Number of bedrooms +1) X 40 gallons = Daily flow in gallons per day (GPD)
4. The application rate is determined based on soil type as shown in the table below

Soil Type	Square Feet per 100 GPD	GPD per Square Foot
Coarse sand or gravel	20	5.0
Fine Sand	25	4.0
Sandy Loam	40	2.5
Sandy Clay	60	1.7
Clay with Considerable Sand or Gravel	90	1.1
Clay with Small Amounts of Sand or Gravel	120	0.8

5. Non-residential graywater systems shall be designed by qualified professional. Design flow is based on average measured historic flows for the particular operation or measured average flows of similar operations shall include a safety factor equal to at least 50%.
6. Non-potable water reuse shall not be authorized within residential structures. Any non-potable water re-use in non-residential structures is subject to case by case review by the Director. At a minimum, such systems shall be designed by a qualified professional and shall be subject to an operating permit.
7. The applicant shall be responsible for obtaining necessary permits or clearances from the Building department regarding drain, waste and vent plumbing within the structure.
8. No permit or approval shall be given by the Department for a graywater system in any city or special district where such systems are expressly prohibited.